

BRAILLO ● 300 S2

**Uncontested Performance & Quality, Now
With Updated Features & Unbeatable Price**



- Rugged construction for large volume Braille production - a true Braille production printer.
- Low noise.
- Prints both 6 and 8 dot Braille.
- Modular design, easy to service.
- Uses standard continuous/fanfold paper in a variety of formats.
- Prints simultaneously on both sides of paper (interpoint).
- 2 year warranty on parts.
- 900 pages per hour of continuous Braille printing.
- Highest quality Braille, making Braillo Braille easiest to read.
- Nearly 30 years of reliability and durability - ask for references

See detailed descriptions at www.braillo.com

BRAILLO ● NORWAY

Technical Specifications Braillo 300 S2

Format:

Char. per line: 10 - 42 characters
Sheet length: 4 - 14 inches
Sheet width: 140 - 330 mm, 5.5 - 13 inches
Page layout: Normal / Z-fold
Page 1: Up / Down
Printing Mode: Single / Interpoint
Braille cell: Standard medium 6 or 8 dot
Line spacing: From 0.3175 to 10.16 mm. (Standard is 5.08 mm)
Paper Weight: 120 - 180 g/m², (Recommended 150 g/m² or 100 lb)

Printing Speed: 300 characters per second, approx. 900 pages per hour

Electrical:

Voltage: Single phase 230V (+/- 10 %), 50/60Hz Approx. 4 A
Current: max
Fuse Printer: 10 A
Power: Approx. 1000 W max

Communication with the computer:

USB
Ethernet

Environment:

Temperatures: 15 - 30°C (60 - 86°F)
Rel. Humidity: 40 - 60%

Measurements:

Height: 650 mm, 25"
Width: 700 mm, 27"
Length: 920 mm, 37"
Weight: 122 kilos, 270 pounds

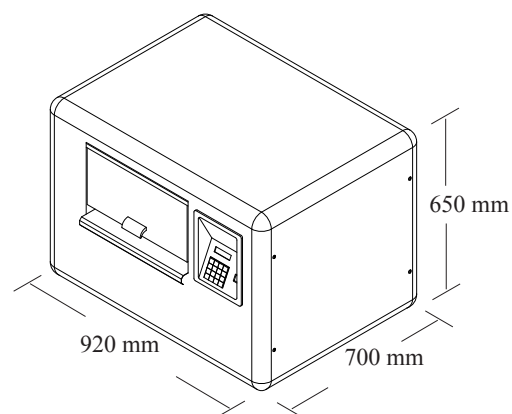

The manufacturer reserves the right to change the specifications without further notice.

Produced and marketed by:

Distributed by:

BRAILLO NORWAY AS

P. O. Box 447
3101 Tønsberg, Norway

Phone: +47 33 00 28 70

Fax: +47 33 00 28 71

E-mail: sales@braillo.com

Internet: www.braillo.com
