

BRAILLO 300



User's Guide

TABLE OF CONTENTS

1.	PRINTER BASIC	5
2.	INSTALLATION	6
2.1	Unpacking	7
2.2	Removal of cover	8
2.3	Connecting the printer to the mains and computer	10
2.4	Power on	12
3.	OPERATING THE PRINTER	13
3.1	Inserting paper	13
3.2	Operating panel functions	14
3.3	Explanation of the different menu choices	19
3.4	Messages / Error messages	27
3.5	Test print	30
4.	SERVICE AND MAINTENANCE	31
4.1	Printing principle	31
4.2	Troubleshooting, incorrect Braille	37
4.3	Magnet rack - Removal	40
4.4	Magnet rack - Disassembly, step by step	41
4.5	Magnet - Replacement	43
4.6	Magnet rack - Cleaning	46
4.7	Magnet rack - Adjustment	47
4.8	Magnet rack - Refitting and adjusting	49
4.9	Beam and paper shoes - Overview	55
4.10	Beam and paper shoes - Removal and refitting	56
4.11	Beam - Replacement of short pivot arm	58
4.12	Beam - Replacement of printing pin	59
4.13	Return spring - Adjustment	60
4.14	Eccentrics adjustment, belt tension	61
4.15	Paper shoes - Adjustment	62
4.16	Main sensor wheel - Adjustment	63
4.17	Paper feed assembly - Removing	64
4.18	Paper feed assembly - Adjustment	65
4.19	Inductive sensors - Adjustment	66
4.20	Paper sensor - Replacing	67
4.21	Maintenance	68
5.	PARTS - EXPLODED VIEWS	70
5.1	Magnet rack	70
5.2	Beam	71
5.3	Paper shoe	72
5.4	Paper feed	73
5.5	Shafts, belt	74
5.6	Frame	76

6.	TECHNICAL SPECIFICATIONS	78
6.1	Technical specifications	78
6.2	Electric unit - Overview	79
6.3	How to replace fuses	80
6.4	Main board - Connections	82
6.5	Escape-sequences	83
7.	GENERAL INFORMATION	88
7.1	Declaration of conformity	88
7.2	Warranty	89
	Warranty request form	90
7.3	Addresses and phone numbers	91

1. PRINTER BASIC

Thank you for your purchase of a Braillo 300. Please read this manual carefully before installing and operating this printer.

Features

Prints interpoint, both sides of the page are printed simultaneously.

Prints up to 300 characters per second (the speed on this printer is adjustable between 200 and 300 cps).

Prints up to 900 pages per hour (on a 12-inch sheet).

Self-test system that checks the magnets continuously during printing.

Reliable, sturdy construction.

Safety switches will turn the Printer off if someone accidentally opens the cover while printing.

Printer overview

Please see the figure below:

Note that the “right-hand” and “left-hand” side are referred to as if you were standing behind the printer facing the opening where the paper is inserted into the printer.

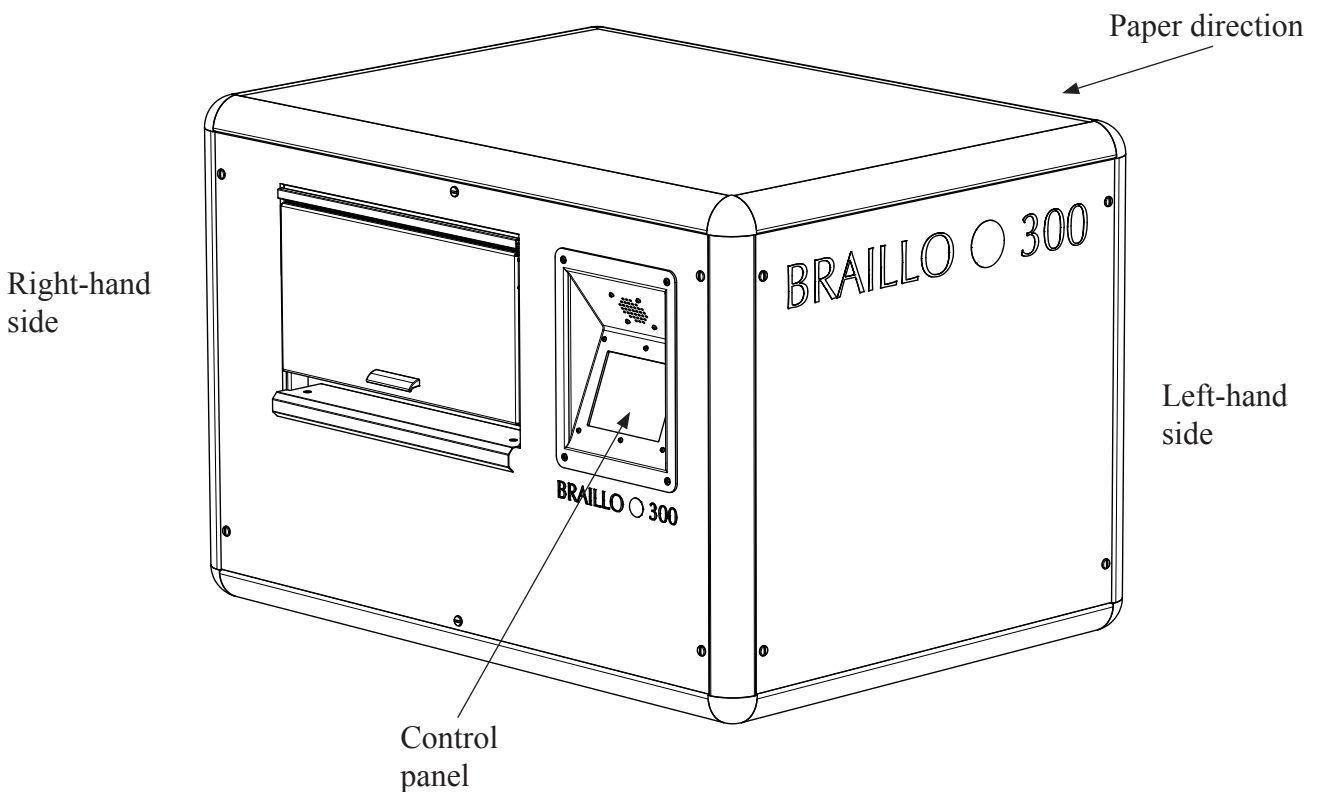

2. INSTALLATION

Table:

The printer should be placed on a sturdy table. Please note that this printer weighs 145 kg.

Space:

The minimum space required for the Braillo 300 is approximately 1.25m x 1.5m (4 x 5 feet). However, it will be more space both behind and around the printer so that one can easily replace the boxes of paper and perform regular maintenance without moving the printer.

Environment:

Braillo Printers are made to operate continuously and to be reliable for many years. However, sensitive electronic and mechanical parts require a suitable installation environment to ensure long and trouble-free operation. Temperature should be between 15° - 30° C (60° - 86° F), and relative humidity between 40 and 60%.

Maintain a clean environment because dust may clog the Printer - especially when combined with high humidity! Too low humidity should also be avoided to prevent electrostatic problems.

Some paper qualities may generate excessive paper dust. This should be removed with a vacuum cleaner and a damp cloth. (About every 50,000 Sheets).

Electrical: Single phase 230 volt (+/- 10%), 50/60 Hz, circuit breakers should be min. 10 amps.

Be sure to consult your distributor/supplier for further details concerning the installation site.

Failure to meet the installation requirements may relieve the supplier of any warranty responsibilities.

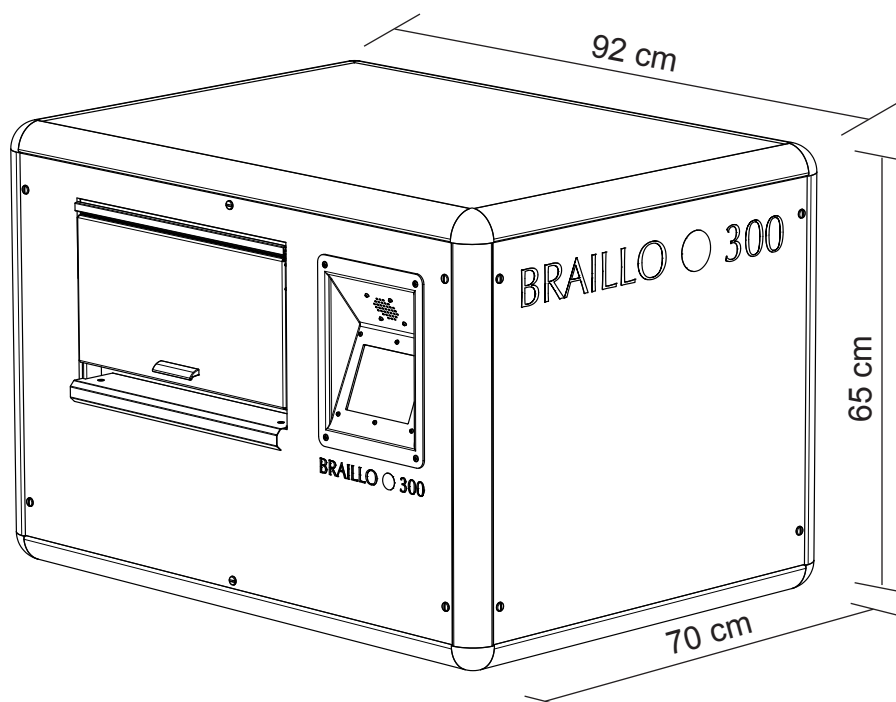

2.1 Unpacking

Unpacking and installation can be done by the user.

After unpacking the printer, the cover must be removed before lifting the printer. See chapter 2.2 “Removal of Cover”.

Any kind of lifting of the printer must always be done from the baseboard at the bottom of the printer, or from the steel frame, and should be done with extreme care.

Make sure that your Braillo printer has not been damaged in transport. Check if the packing is damaged; If so, it is possible that the printer has also been damaged or scratched. If any damages are found, please contact your distributor or Braillo Norway AS immediately.

Also check that the printer is accompanied with the following items:

- 1 Power cable for the printer
- 1 Data cable, USB
- 1 Data cable, ethernet (shielded)
- 1 A small stack of paper
- 1 User’s guide
- 1 Tool kit for service and maintenance
- 1 Test and packing list

If any of these items are missing, please contact your distributor or Braillo Norway AS.



Important !

It is very important that the printer’s specified voltage value (230V, +/- 10%) corresponds with the local mains power supply available.

If the plug on the mains power cable is to be replaced, note that the yellow/green wire is the grounding (earthing) wire.



THE PRINTER MUST ALWAYS BE CONNECTED TO GROUND!

After the printer is unpacked, we advice that the transport box is stored for possible later use.

2.2 Removal of cover

See figure below and on the next page.

The cover is constructed of a aluminium frame which is placed on the baseboard of the printer. Onto this frame the sides, front and back panels are fastened. These panels can be taken off for a better access e.g. to connect to the electrical unit.

However, if the printer is going to be lifted or moved, it is better that the cover is taken off completely.

It can be done like this:

Disconnect the mains.

Open the panel by turning the screws marked (B) 1/4 of a revolution - use a coin or a screwdriver. Pull out the panel. Place it aside.

- Disconnect the cables to the operating panel. Note that these cables is to be disconnected at the end on the back of the operator panel.
- Disconnect the cable to the cover safety switches
- Disconnect the cable to the fans

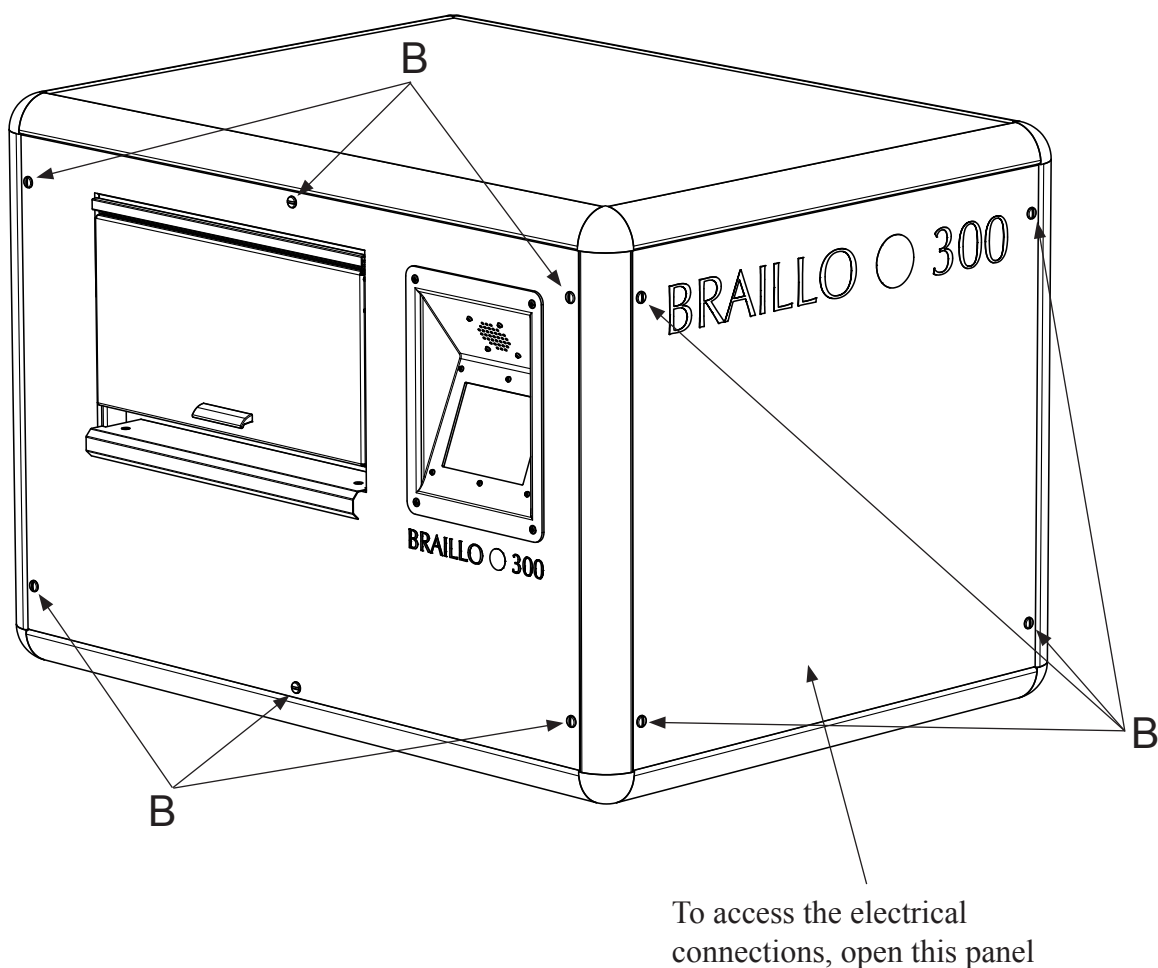

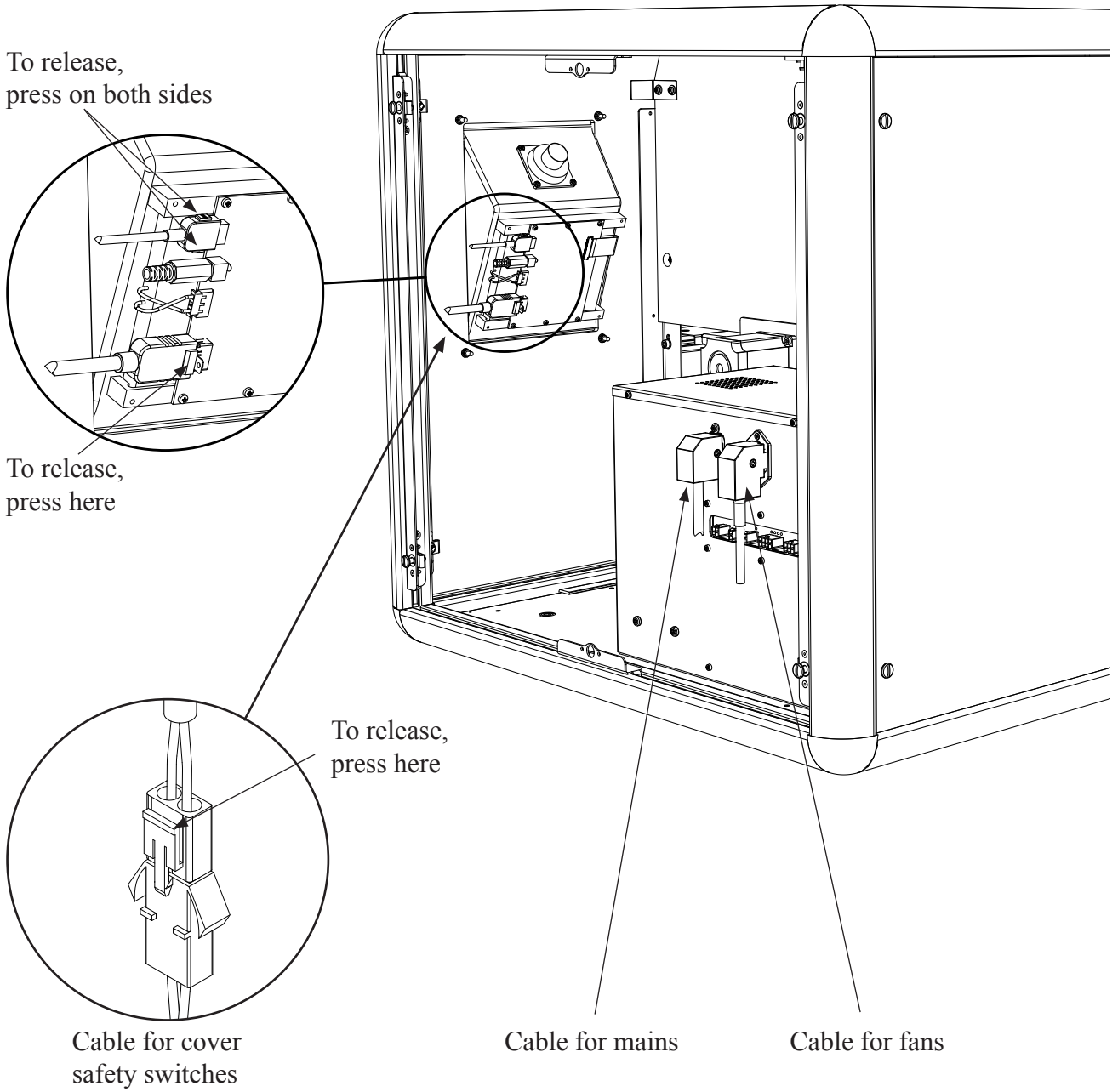

2.3 Connecting the printer to the mains and computer.

The connections are inside the printer, on the electric unit.

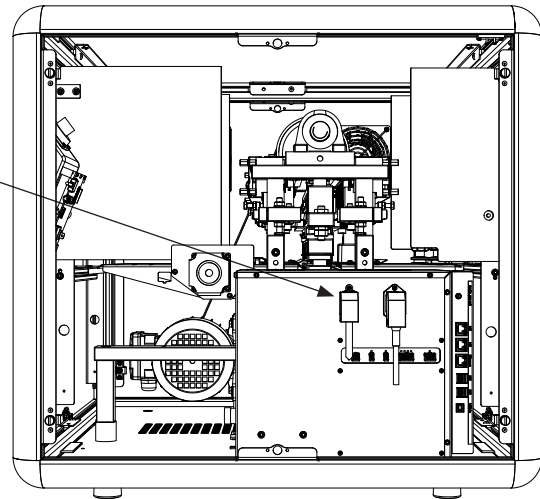

Connecting to the mains

See the figure below.

Connect the enclosed mains power cable to the Mains inlet.

Note! If the plug on the mains power cable is to be replaced with one that is compatible with the local electric contact points, observe that the yellow/green wire is the grounding (earthing) wire. Also make sure that you are connecting to 230 volts!

THE PRINTER'S MAINS CABLE MUST ALWAYS BE CONNECTED TO GROUND!

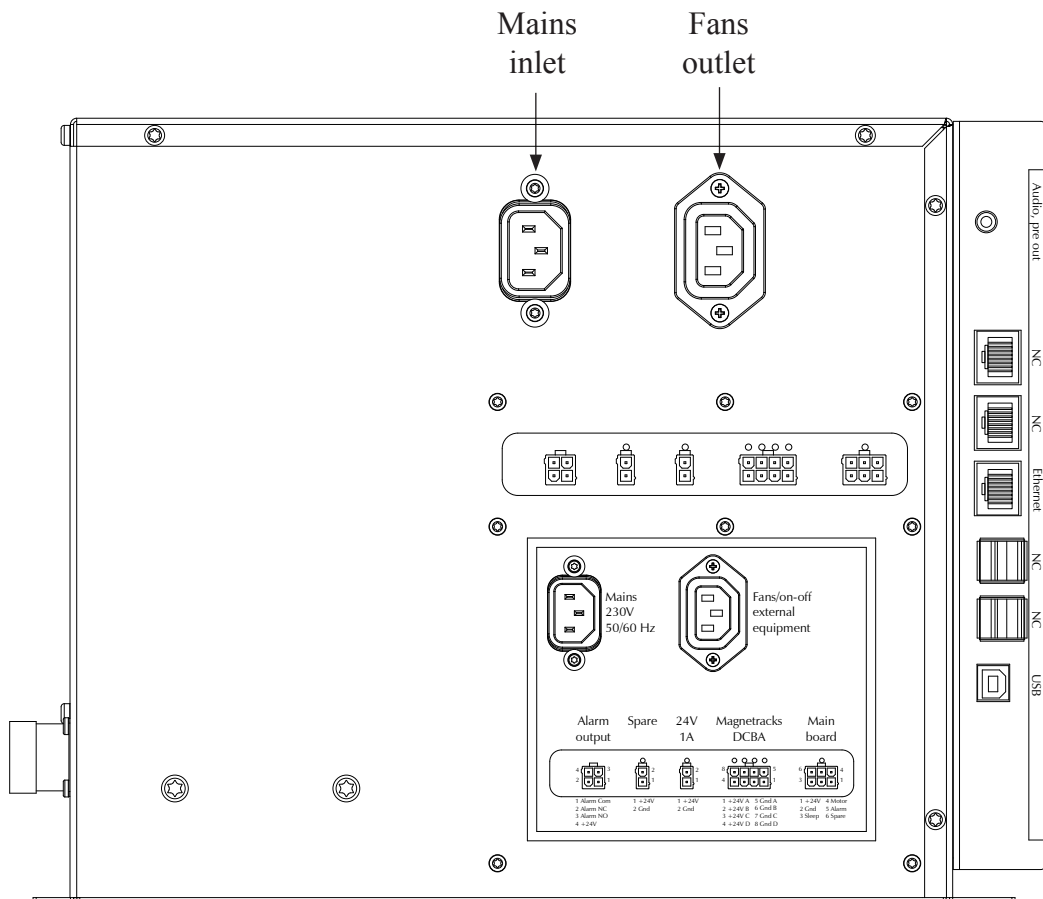

Connecting to the computer

This can be done in two ways, Ethernet or USB.

The ethernet is a RJ45 connector, and the USB is a regular USB connector.

There is no need to select which of the three input to use. The Printer will connect to the input who receives data first. Meaning, if data comes on the ethernet, the USB will not be operative before the ethernet have finished the transmission.

It is a rather large text buffer in the Printer, so the text file will be transferred to the Printer as fast as the transmission will allow. Then the Printer will run until the text buffer is empty.

See figure below, this is a front view of the electrical unit.

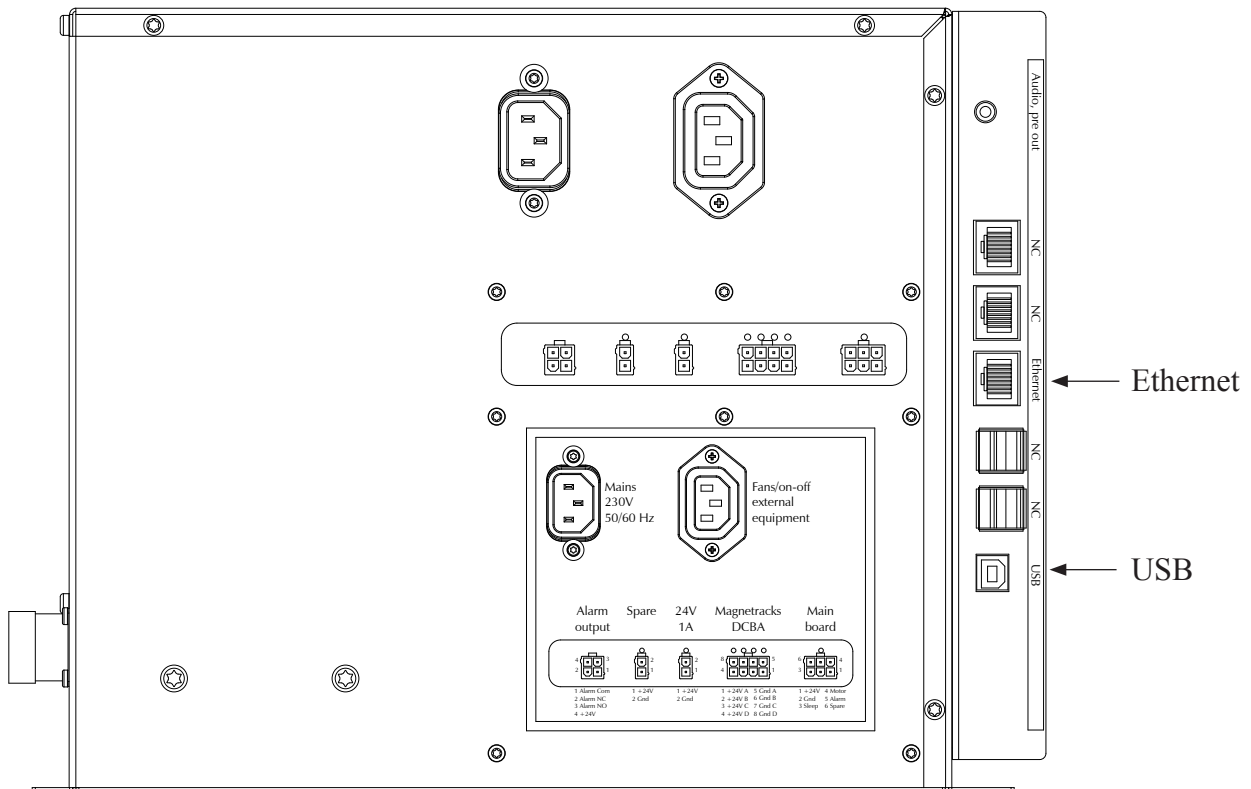

2.4 Power on

This printer does not have an on/off switch, so when the mains cable has been connected, the printer will do its start up sequence. The display will be black for a moment, then it will show a progress bar for the start up sequence. When done, the display will show “Welcome, press the accept button to continue”. Press the key and the display will change to “Ready to emboss”.

 For safety reasons, there are switches on the side panels on the cover. This switches will disable the possibility to run the printer if someone is removing one of the side panels.

Then the paper feed tractor will move a little back and forth to position the paper correctly. If there is no paper inserted, the printer will start an alarm, and the display reads “Printer Out of paper”. This is normal, and the noise can be silenced by pressing the mute button.

Note that the Printer will turn it self off (go into sleep mode) when it has been inactive for 15 minutes. If that happens, the Printer will wake up if you touch the operating panel or send a file from the computer. It is also possible to set it in the sleep mode by entering the main menu, and select the “Enter sleep mode” choice.

The printer is now ready. Now please read the following chapter 3, “Operating the Printer” carefully.

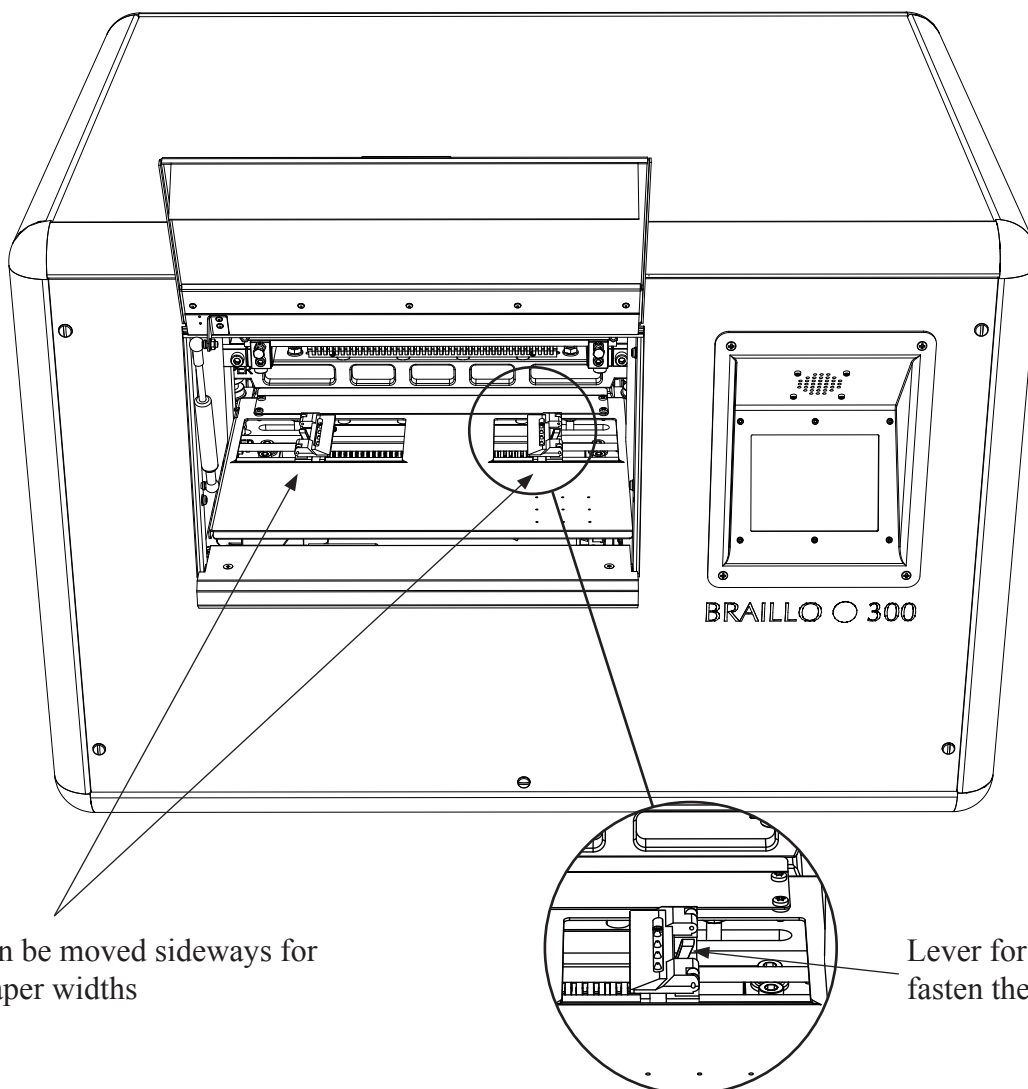

Tractors can be moved sideways for different paper widths

Lever for loosen/ fasten the tractor

3. OPERATING THE PRINTER

3.1 Inserting paper

Paper should be inserted into the printer in the following manner:

1. Place a box of paper at the back of the printer. (Opposite side from the operating panel).
2. Insert the paper between the two paper guides, and then through the slit in the paper guide. Insert about the length of one sheet. Go to the front of the printer.
3. The tractors might have to be adjusted sideways to fit to the paper width in use. This is done by opening a little lever on the outer side of the tractors, then move the tractors so it will fit to the paper width, then close the lever again.
4. Lock the paper into the tractor-feed. By using the FINE ADJUST button, adjust the paper with respect to the starting mark (notch) corresponding to the chosen sheet length. (See figure below).
5. Go to the back of the printer, and adjust the two paper guides carefully close to the edge of the paper. This is to ensure that the paper will go straight trough the printer. The printer is now ready to start printing.



Note! If the printer has run out of paper during a print job, perform step 2 to 5, without resetting the printer. Press the “Continue” button, and the printer will continue from the place where it ran out of paper without losing any text.

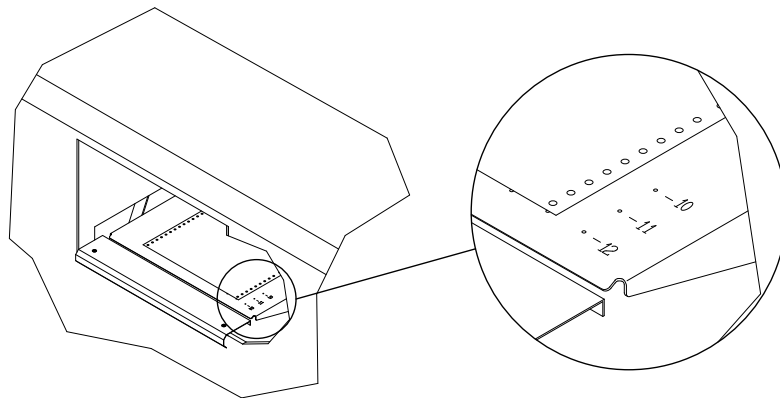

Use the marking that corresponds to the sheet length in use

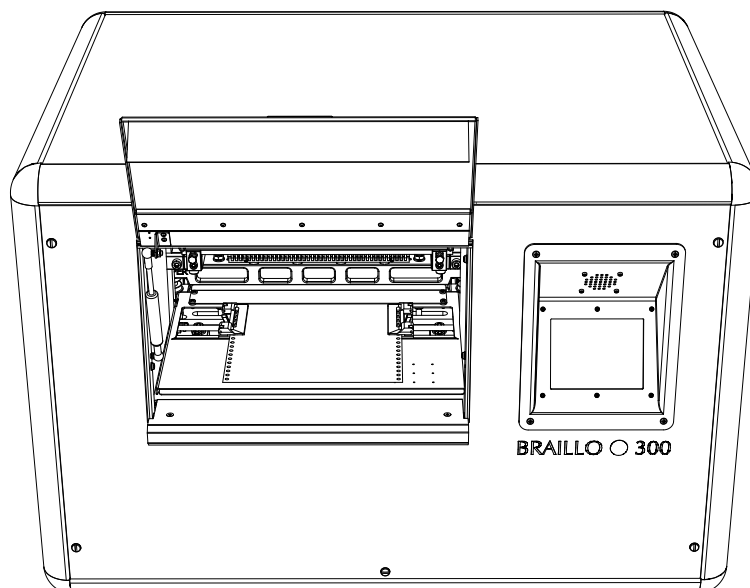

Ready to go!

3.2 Operating panel functions

When the printer is powered up, you have to press the “Accept button” to make the printer ready.



Accept button

After pressing “Accept” the window below appears. Please see the explanation on the figure below:

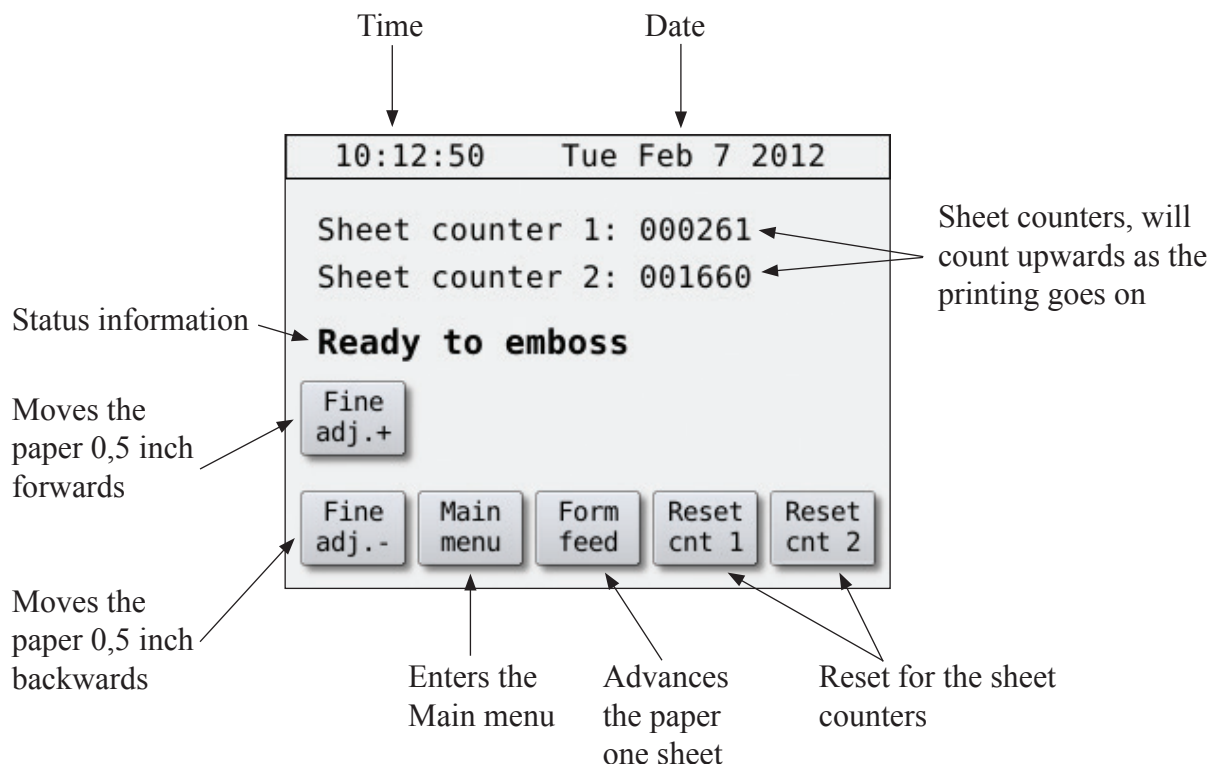

Navigating in the menus.

Move the cursor the desired sub menu, and then press the accept button.

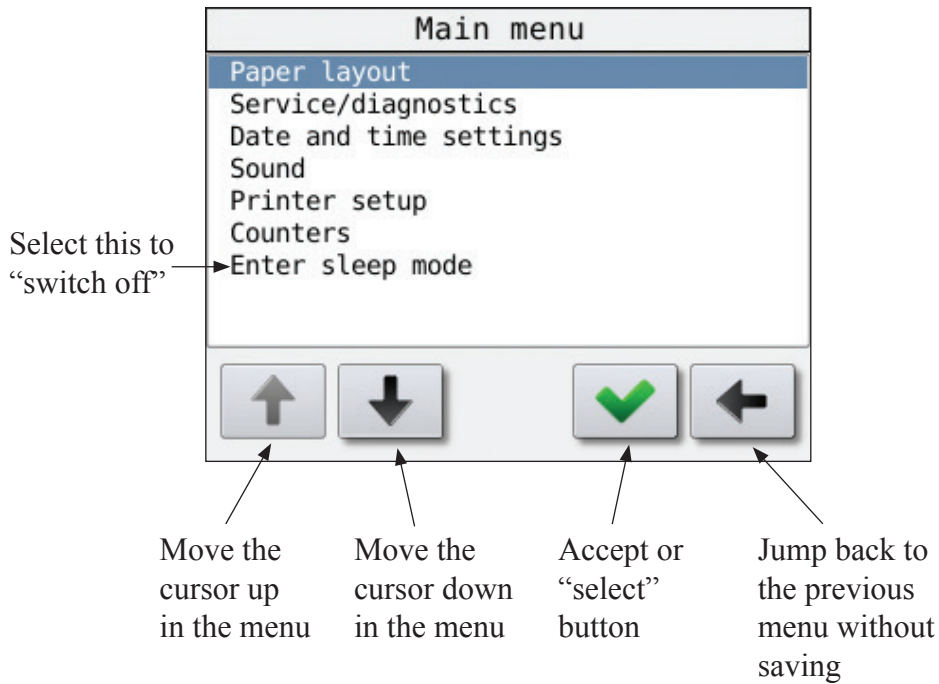

To change a variable setting.

If a setting can have more than two values, the display will look like below.

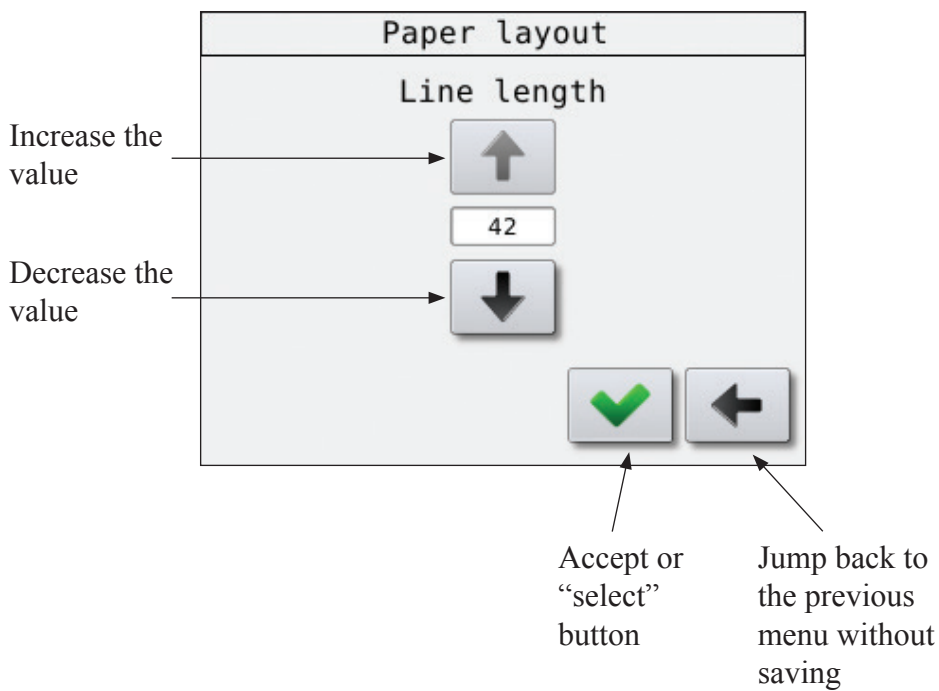

To change a setting with just two alternatives.

If a setting can have just two alternatives, the display will look similar to this.

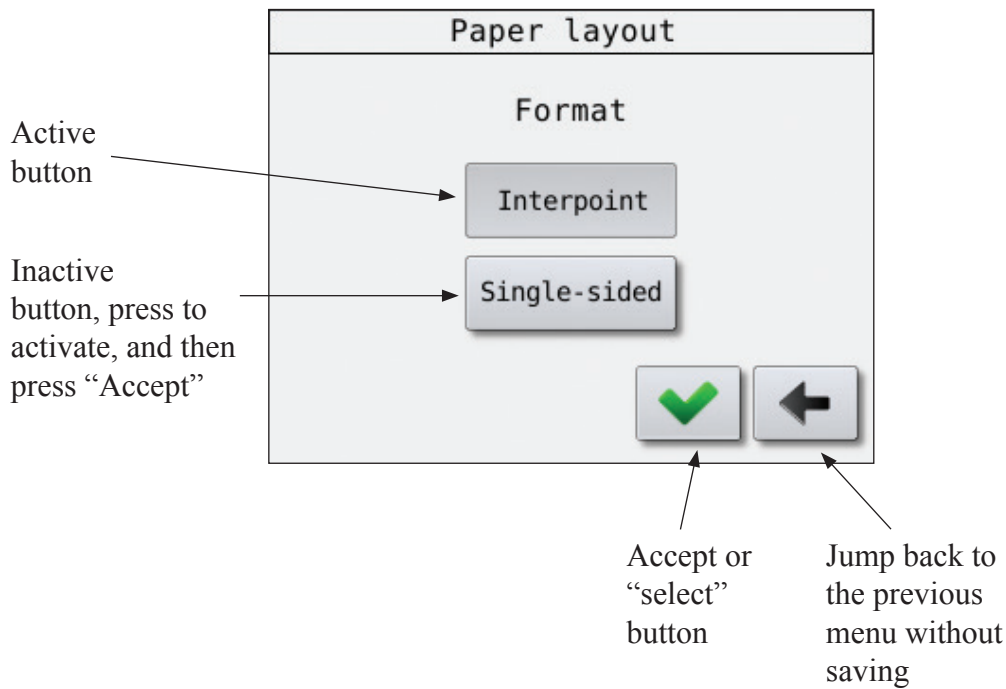

The very first time the printer is powered up, you have to select the printer model.

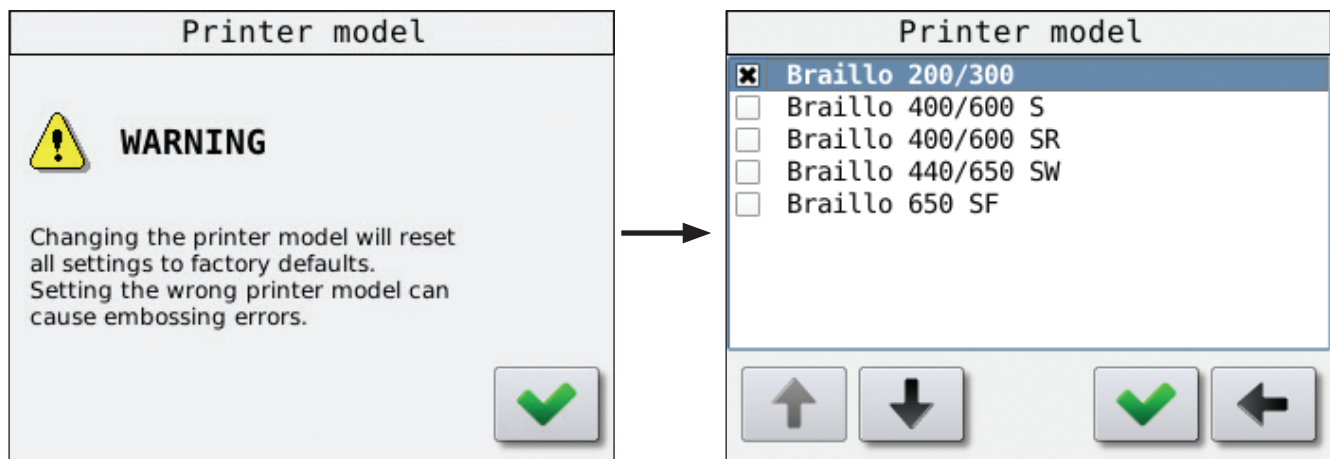

Note!

The settings set by the operator panel is the default values. However, when sending a text file from the computer, some parameters for this specific job is sent along with the file. The parameters that comes with the file will be active during the print job. When the job is finished, the settings will return to the default settings again.

Operator panel during printing.

Please see the figure below:

Embossing Sheet 1 / 5 means that the Printer are now printing Sheet 1 of a book with 5 sheets in total. Copy 1 / 1 means there will be just one copy.

If you would like to pause a print job, press the “Pause” button. When the Printer is paused, the button will change to “Continue”. Press “Continue” to continue with the printing. If you would like to cancel the rest of the print job, press “Reset”.

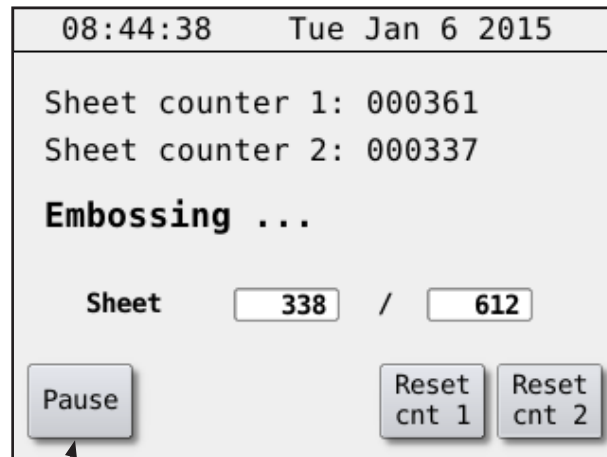

Press this button if you want to pause the print job.

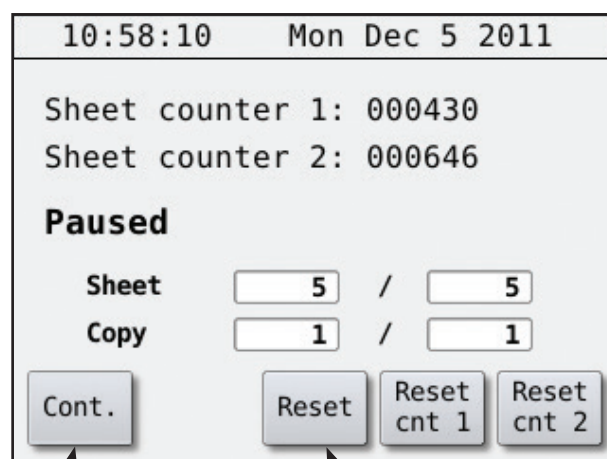

Press this button if you want to continue the print job.

Press this button if you want to cancel the rest of the print job.

Overview of the menu structure.

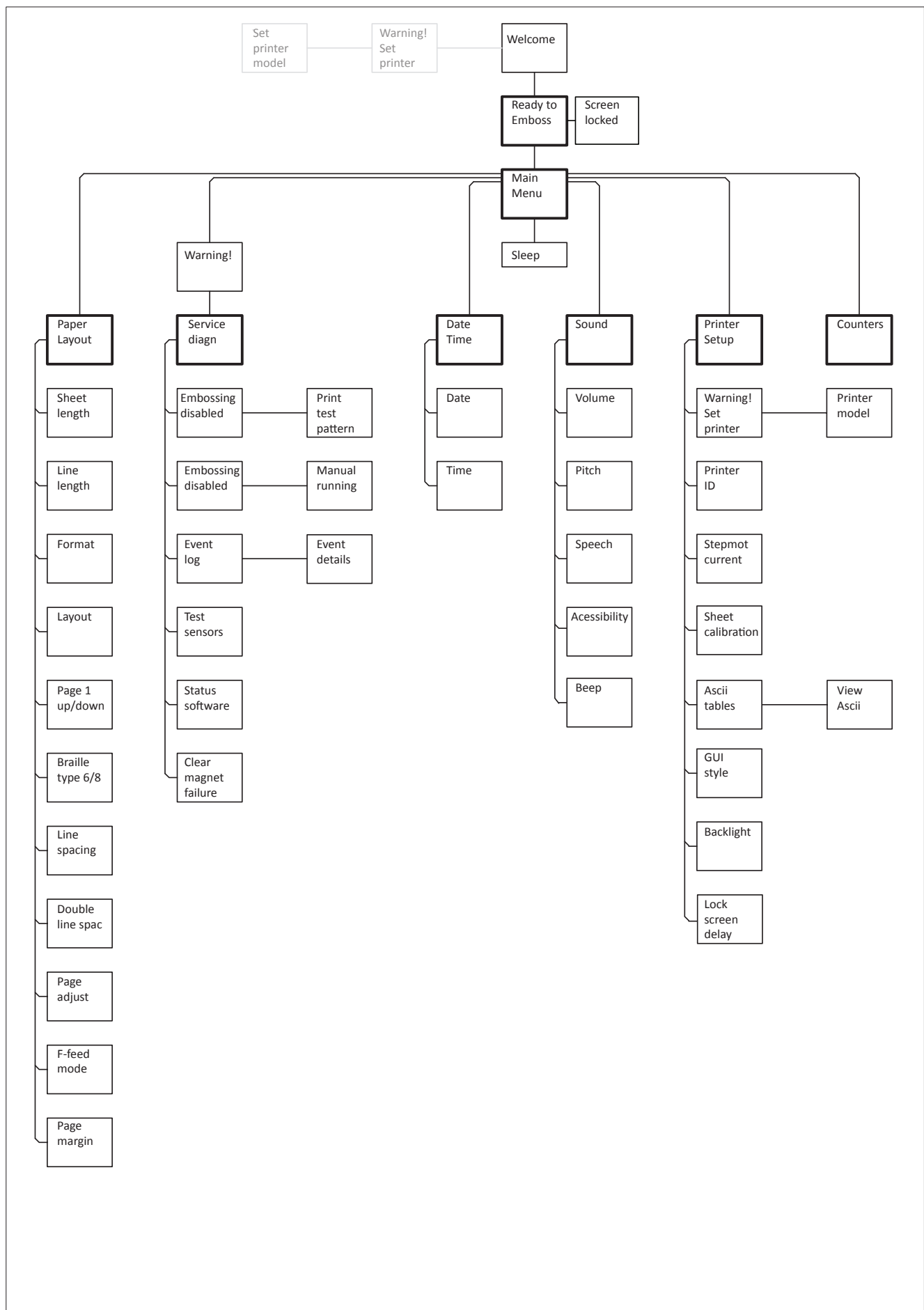

3.3 Explanation of the different menu choices.

The Paper Layout menu

Main Menu - Paper Layout

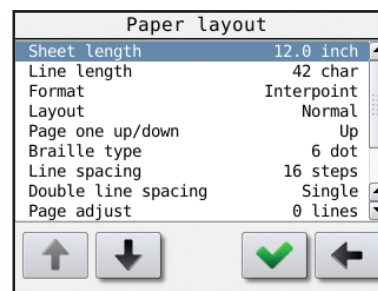

Sheet length:

Main Menu - Paper Layout - Sheet Length

The sheet length is the length of the sheet in inches. The range is from 4 to 14 inches.

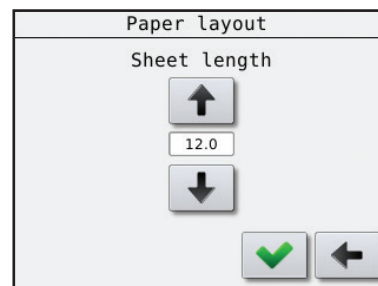

Line length:

Main Menu - Paper Layout - Line Length

The line length is the maximum number of characters that you can have on a single Braille line. The range is from 10 to 42 characters.

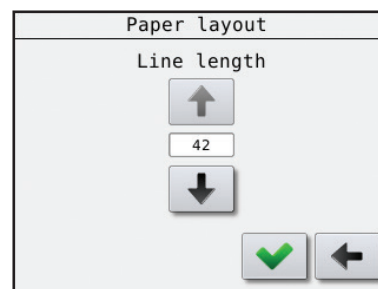

Format:

Main Menu - Paper Layout - Format

Selects between Interpoint (dots on both sides of the sheet) and Single sided (dots on just one side of the sheet).

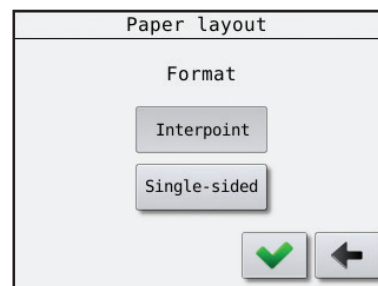

Layout:

Main Menu - Paper Layout - Layout

Selects between Normal and Z-fold mode. Normal means that the Braille is organized on the sheet like this:

Sheet no. 1 contains page no. 1 and 2,

Sheet no. 2 contains page no. 3 and 4, and so on.

Z-fold is like this:

Sheet no. 1 contains page no. 1 and 2,

Sheet no. 2 contains page no. 3 and 4, but upside down

Sheet no. 3 contains page no. 5 and 6,

Sheet no. 4 contains page no. 7 and 8, but upside down

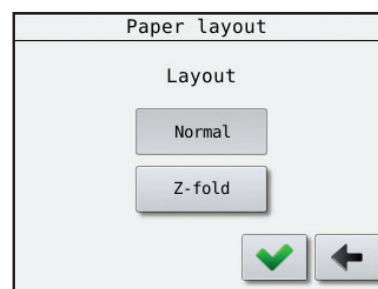

Page one up/down:

Main Menu - Paper Layout - Page one up/down

Selects if page one is on the top or underside of the sheet. The rest of the pages will also adjust accordingly.

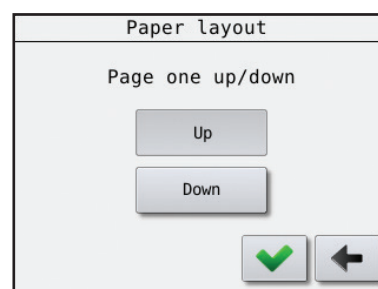

Braille type:

Main Menu - Paper Layout - Braille type

Selects between 6 and 8 dot mode.

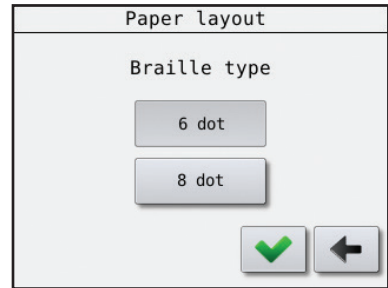

Line spacing:

Main Menu - Paper Layout - Line spacing

Selects the Line spacing. The range is from 0 to 16.

16 steps are the standard line spacing (5.08 mm or 0.2”), 8 is the setting for making dots continuously down the sheet (line spacing is 2.54 mm or 0.1”). Note that if the setting is less than 7, and there is text on each line, the dots might get damaged in the printing process. Normal setting is 16 steps.

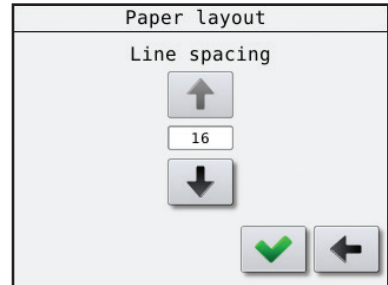

Double line spacing:

Main Menu - Paper Layout - Double line spacing

The function “Single or Double line spacing” will double the given line spacing. If, e.g. the current line spacing is 13 steps (4.1275 mm), selecting Double line spacing will increase it to 26 steps (8.2550 mm). Normal setting is Single Line Spacing.

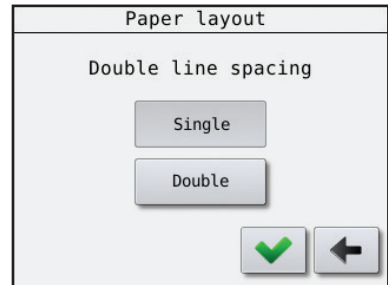

Page adjust:

Main Menu - Paper Layout - Page adjust

This setting will decrease the number of lines on each page from 0 to 9. If the maximum number of lines could be 29, and the setting “Max-4” is selected, the resulting number of lines will be 25. This function will keep the top margin constant and only the bottom margin will vary. The normal setting is 0.

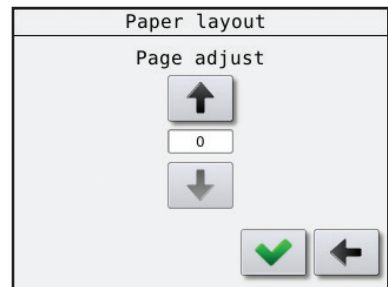

Form feed mode:

Main Menu - Paper Layout - Form feed mode

Selects between Normal Form Feed or No Form Feed. Normal setting is Normal Form Feed.

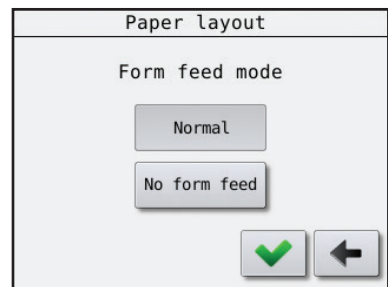

Page margin:

Main Menu - Paper Layout - Page margin

The “Page Margin” function will adjust the page margin in steps from 0 to 20. The standard setting is 8, (8 = normal). One step is equal to 0.6350 mm. It will “push” the text downwards the sheet (like a top margin). If the text reaches the bottom, (meaning that there will not be enough space on this page for the last line), this line will wrap over to the next page. The normal setting is 8 steps.

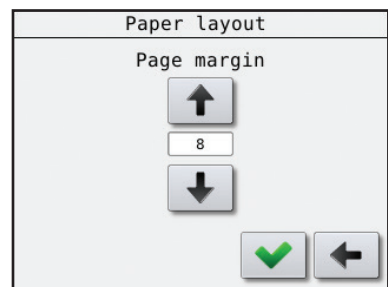

The Service/Diagnostic menu

Main Menu - Warning - Service/Diagnostic

When entering this menu choice, a warning window will appear.

The purpose of this warning is make the user aware that the safety switches on the cover is now disabled. This is done to make it possible to run smaller tests during service.



Please be aware of rotating parts to prevent injuries!
The Printer may be unexpectedly started by other users!

To make sure you have absolutely control when doing service with the power connected, disconnect the computer cables (ethernet and USB).

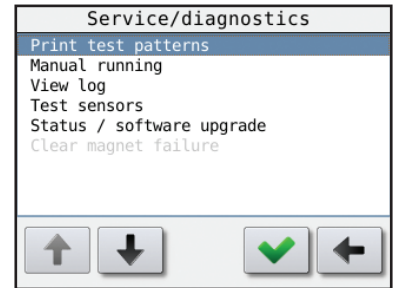

Print Test Pattern:

Main Menu - Warning - Service/Diagnostic - Warning - Print Test Pattern

When entering this menu choice, a warning window will appear.

This is to make the user aware that print jobs from the computer will not be printed as long as you are in this sub-menu.

- X pattern.

Will print dots in a x pattern across the sheet, useful when searching for missing dots.

- Full cell, single sided.

Prints all six dots on all characters on one side of the sheet, useful for dot quality tests.

- Full cell, both sides.

Prints all six dots on all characters on both sides of the sheet, useful for testing the paper quality.

- O/Ø pattern.

Prints a test pattern made of dot 1,3,5 and 2,4,6, single-sided, useful when searching for extra dots.

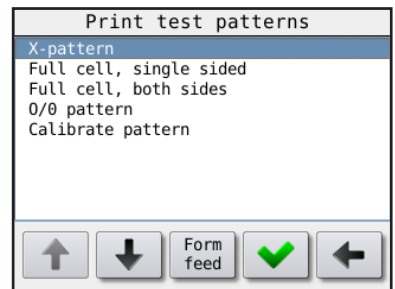

Manual Running:

Main Menu - Warning - Service/Diagnostic - Warning - Manual Running

When entering this menu choice, a warning window will appear. This is to make the user aware that print jobs from the computer will not be printed as long as you are in this sub-menu.

The function of this menu choice is to activate different functions manually for troubleshooting purposes.

- Main motor

Use this to manually start and stop the main motor.

- Step motor

Will run the stepping motor forward approximately one sheet.

- Stepmotor Reset

Reset the step motor driver.

- X pattern without motor

Will activate one and one magnet on the magnet racks.

- Sleep relay

Turn the Sleep relay on or off.

- Alarm relay

Turn the Alarm relay on or off.

- Spare relay

Turn the Spare relay on or off.

View Log:

Main Menu - Warning - Service/Diagnostic - Warning - View Log

The Printer remembers the different events that has happened and will store them in a log. This log can be viewed in a list like the figure to the right. If a message is repeated several times, the display will show a line with the text “last message repeated x times”.

Use the up and down arrow to scroll the list.

If the “OK” button is shown in green, it is also possible to view some more details about this particular event by pressing the “OK” button.

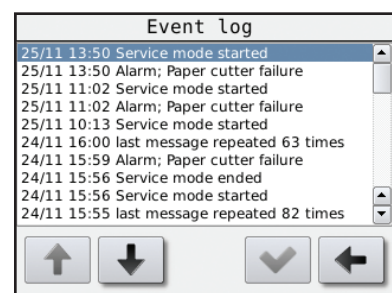
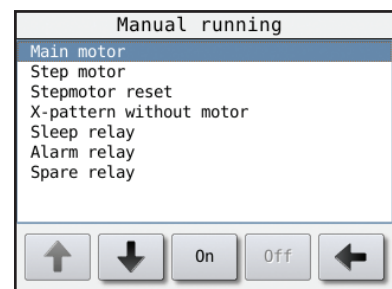
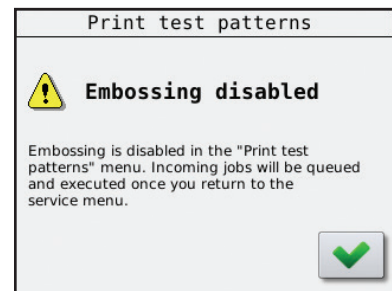

Test Sensors:

Main Menu - Warning - Service/Diagnostic - Test Sensors

This is a function made for troubleshooting the sensors on the Printer. The “On” or “Off” is indicating the current status of the sensor.

To find out if a sensor is OK, the sensor can be switched on and off physically, and the text in the display will change between “On” and “Off” accordingly if the sensor is functioning.

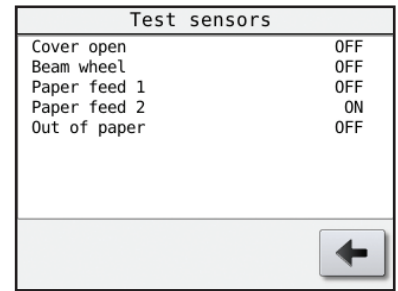

- Cover open

This is the switches on the side panels on the Printer.

- Beam Wheel

This is the sensor fitted on the lower shaft on the Printer.

- Paper feed 1

This is the first sensor on the paper transportation in the Printer.

- Paper feed 2

This is the second sensor on the paper transportation in the Printer.

- Out of paper

This is a sensor that check if there is paper present in the Printer. It’s fitted on the paper guide on the input side of the Printer.

Status Software:

Main Menu - Warning - Service/Diagnostic - Status Software

A window that will show the Printers current IP address, the MAC address and the Software version.

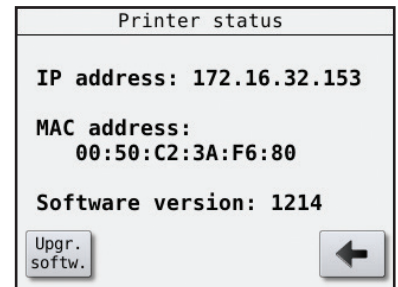

Clear Magnet Failure:

Main Menu - Warning - Service/Diagnostic - Clear Magnet Failure

This menu choice is normally not visible, but if there has been detected a faulty magnet during printing, a magnet icon will be shown in the “Ready to emboss” window. Now the “Clear Magnet Failure” becomes visible in the “Service/Diagnostics” menu and here the magnet icon can be reset.

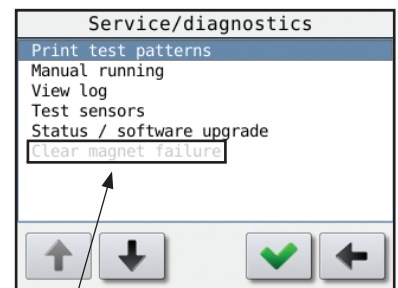

The Clear magnet failure choice

The Date and Time menu

Date and Time:

Main Menu - Date and Time

Used to change the date and time setting

- Date

Main Menu - Date and Time - Date

Used to change the date.

- Time

Main Menu - Date and Time - Time

Used to change the time.

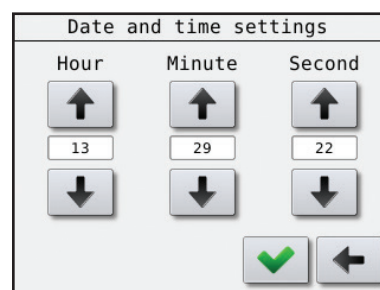
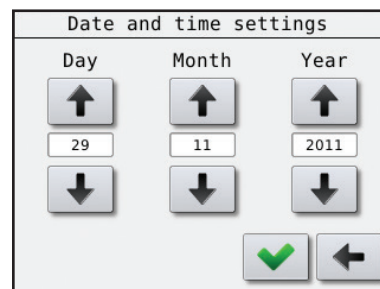
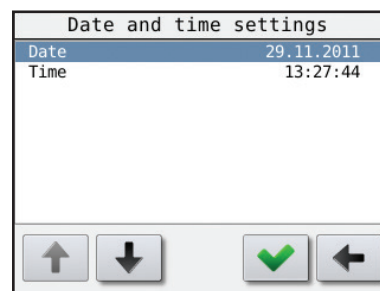

The Sound menu

Main Menu - Sound

- Volume

Main Menu - Sound - Volume

Volume setting for beep and speech.

- Pitch

Main Menu - Sound - Pitch

Sets the pitch level for the beep.

- Speech

Main Menu - Sound - Speech

Toggles Speech on or off.

- Accessibility

Main Menu - Sound - Accessibility

Toggles *Accessibility* on or off.

- Beep

Main Menu - Sound - Beep

Toggles Beep on or off.

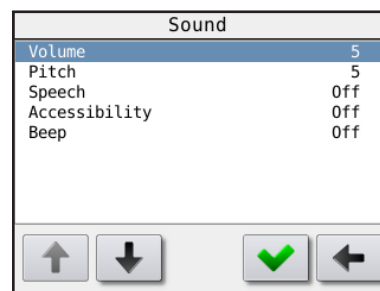

The Printer Setup menu

Main Menu - Printer Setup

In this menu the basic settings regarding the Printer is set.

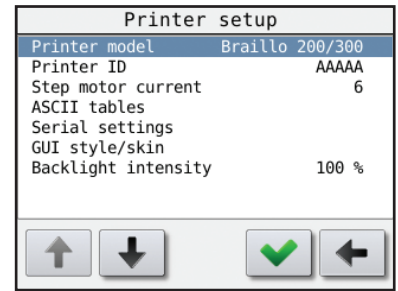

Printer model:

Main Menu - Printer Setup - Warning - Printer model

When entering this menu choice, a warning window will appear.

Braillo Norway has a number of different Printer models that can use the same electronics. But the different Printer models have different settings and different functions. This menu choice is where you select the specific Printer model. The software will then be adapted to the Printer in use.

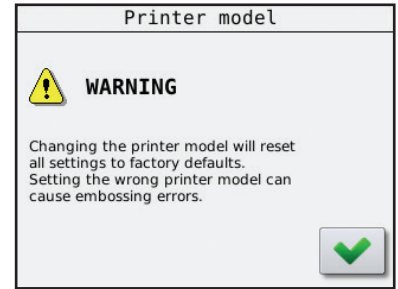

This setting is fixed at the factory, and should under normal conditions never be changed.

However, if for some reason the main board on the Printer has been replaced, this menu will appear on the first power up.

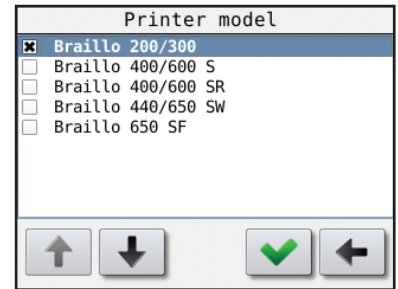

Printer ID:

Main Menu - Printer Setup - Printer ID

The Printer has a function to make it possible to identify which Printer has printed a particular Braille book. It is done by sending a command along with the Braille book that tells the Printer to print it's identification. On this setting you can set a 5 character code or name that identifies this particular Printer.

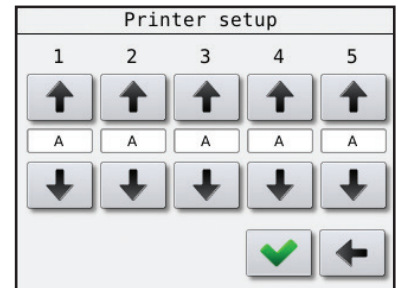

Step motor current:

Main Menu - Printer Setup - Step motor current

It is possible to adjust the current on the step motor (paper feed motor) from 0 to 11. The motors torque will be proportional to this value. The default setting is 6. Should not need to be changed.

ASCII tables:

Main Menu - Printer Setup - ASCII tables

An ASCII table is the same as a character set. When the Printer receives a character from the computer, it goes to an ASCII table to find out which dot pattern is corresponding to this character.

This Printer has a number of ASCII tables, and they are listed like shown in the figure to the right. To select another table, use the up or down arrow and press the green “OK” button. Now this has become the current table.

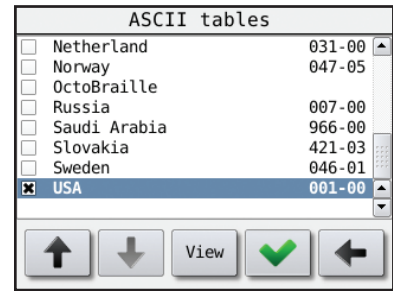

It is also possible to view the translation between characters and dots in the different ASCII tables by pressing the “View” button.

Then a list like shown on the right will appear. Use the up and down arrows to scroll the list.

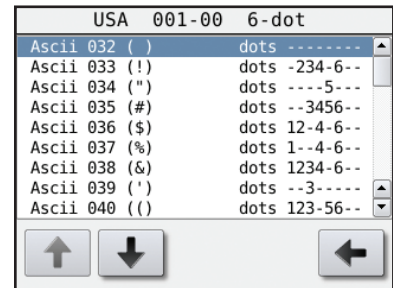

GUI style/skin:

Main Menu - Printer Setup - GUI style/skin

If any users of this Printer has low vision and/or find it a bit difficult to read the operator panel, it is possible to change the background and text colours to get better contrasts.



Back light intensity:

Main Menu - Printer Setup - Back light intensity

The back light intensity on the operator panel can be adjusted from 0 to 11.

Lock screen delay:

Main Menu - screen locked

Selecting the delay before screen get locked, 0 is screen lock off.

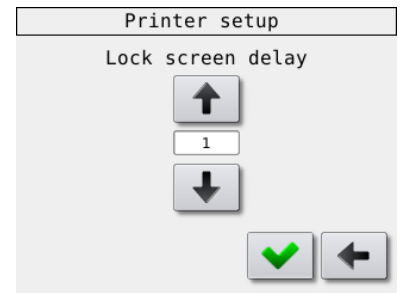

The Counters menu

Main Menu - Counters

Will show two different counters, the first one will show the total number of sheets printed. The second shows the total number of hours the main motor has been running. (The time the Printer has actually printed).

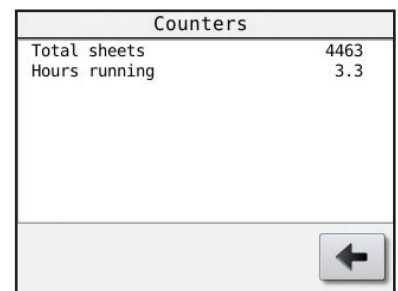

3.4 Messages/Error Messages

Messages/Error Messages on this Printer can be divided into three groups; Messages, Error Messages and unrecoverable Error messages.

Messages:

- Magnet failure

Defect magnets has been detected during printing. If the number of defect magnets is less then 5, the Printer will continue printing. Please note that Sheet counter 2 has changed to show the number of sheets printed since the failure appeared. If the number of defect magnets is 5 or more, the display will say “General failure, Magnet rack failure” and the Printer will stop. Please check the log for the details. *(Main Menu - Warning - Service/Diagnostic - Warning - View Log)*

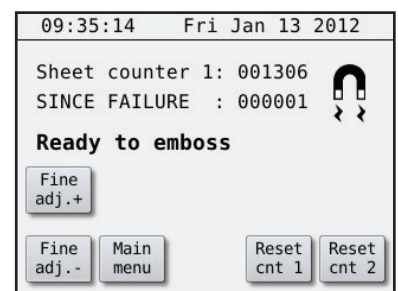

To reset the magnet failure message (after the repair), you have to press the menu choice “Clear Magnet Failure”.

(Main Menu - Warning - Service/Diagnostic - Clear Magnet Failure)

Recoverable errors:

When there is a recoverable error, the display will show what has happened e. g. “Printer halted, Printer cover open”. And it will stay like that until the error is fixed. Then the display will change to “Printer halted, Press continue to resume”. By pressing “Continue” the Printer will resume the printing from where it was before.

The different recoverable errors are:

- Printer cover open

This occurs when one or more open side panels on the Printer cover are open. When the side panels are put back in place, the display will change to “Press continue to resume”.

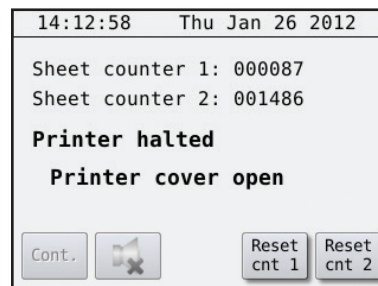

- Out of paper

The Printer has run out of paper and are waiting for more paper. When more paper is detected, the display will change to “Press continue to resume”.

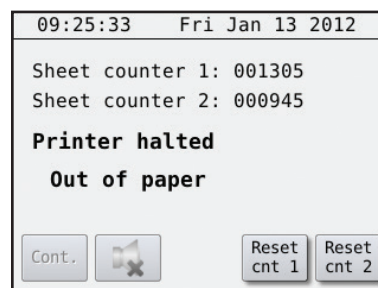

- Press continue to resume

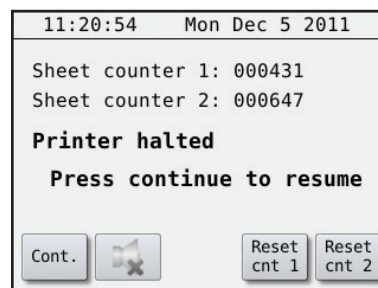

Unrecoverable errors:

When there is a unrecoverable error, the display will show what has happened e. g. “General failure, Beam wheel failure”. When this kind of errors occur, the Printer must be reset or switched off and then switched back on again.

The job currently being printed has to be sent once more from the computer. The different unrecoverable errors are:

- Beam wheel failure

This means that the pulses from the Beam wheel sensor is not registered in the electronics. This can be caused by; e.g. defect sensor, disconnected sensor, broken main belt and defect main motor. If you can hear the main motor start, it is probably something wrong with the sensor. But if you cannot hear the motor start, it is probably something wrong with the main motor. Press Reset to continue. Tip; The sensor can be tested manually on *Main Menu - Warning - Service/Diagnostic - Test Sensors*.

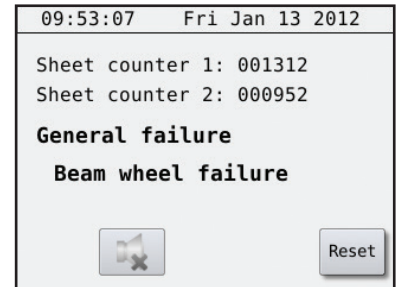

- Magnet rack failure

The magnet self test system has detected problems with 5 magnets or more. It is not very likely that more than one magnet will go bad at the same time, so when this failure appears, it is more likely caused by e.g. disconnected cables to the magnet rack or a blown fuse. Press Reset to continue. Please check the log for the details.
(*Main Menu - Warning - Service/Diagnostic - Warning - View Log*)

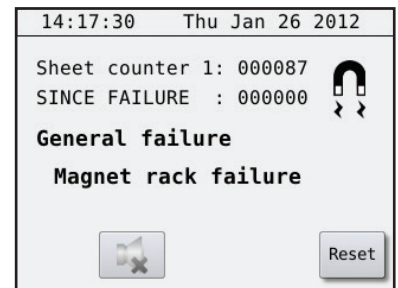

- Paper feed failure

The paper position is not where the electronics is expecting it to be. This may be caused by e.g. the paper is stuck so the stepping motor is slipping, stepping motor is disconnected or defect, and one of the two sensors is disconnected or defect. Press Reset to continue. Tip; The sensors can be tested manually on *Main Menu - Warning - Service/Diagnostic - Test Sensors*.

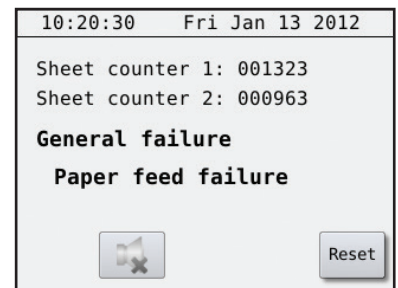

- Illegal ESC sequence

The Printer has received an ESC sequence that it doesn't recognize or is placed in wrong location on the page or with invalid parameters. Press OK to continue.

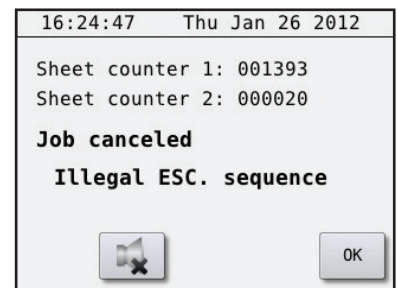

3.5 Test Print

The test print program is designed to ensure that the 168 printing mechanisms functions properly.

This Printer will do an electronic test on all of it's printing mechanisms continuously during printing. However, this electrical test will not tell if something is wrong mechanically, and therefore it is recommended to print a few pages of test print before beginning the day's production.

By doing so, it's quite easy to see if all printing mechanisms are functioning mechanically.

This Printer has both single-sided and double-sided (interpoint) test print patterns.

The test print consists of four different patterns. See the description below:

How to use the test print:

Print Test Pattern:

Main Menu - Warning - Service/Diagnostic - Warning - Print Test Pattern

When entering this menu choice, a warning window will appear. This is to make the user aware that print jobs from the computer will not be printed as long as you are in this sub-menu.

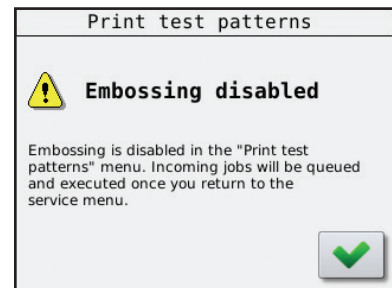

- X pattern

Will print dots in a x pattern across the sheet, useful when searching for missing dots.

- Full cell, single sided

Prints all six dots on all characters on one side of the sheet, useful for dot quality tests.

- Full cell, both sides

Prints all six dots on all characters on both sides of the sheet, useful for testing how the paper quality can take heavy printing.

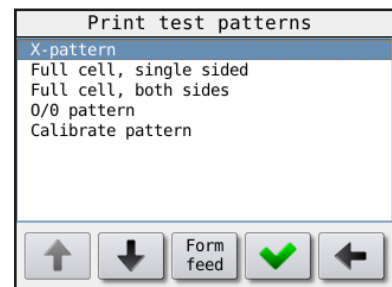

- O/O pattern

Prints a test pattern made of dot 1,3,5 and 2,4,6, single-sided, useful when searching for extra dots.

The chapter 4.1 "Printing principle" illustrates how the printing mechanisms are placed.

Instruction for troubleshooting will be illustrated by examples in chapter 4.2 "Troubleshooting, incorrect Braille".

4. SERVICE AND MAINTENANCE

When doing service or maintenance, the cover must be taken off. Some procedures covered in this chapter might be done simply by removing for example a side panel. But we recommend for “bigger operations” to remove the cover completely. Please see chapter 2.2 “Removal of cover” on how to do this.

When the cover is removed, the operator panel is also removed. To be able to run tests and so on, you can place the cover beside the printer so that you are able to connect the cables to the operator panel. Or you can unscrew the panel from the cover and keep it nearby the printer.

Please observe that the operator panel is an electrical board, and **MUST NEVER BE LAID ON A CONDUCTIVE SURFACE!** If there is a short circuit on the board, it might damage the board.

4.1 Printing principle

The figure below is a very simplified version of the printing mechanisms in this printer.

The four “bars” across the paper indicates the magnet racks.

The magnet racks are named from A to D.

Magnet rack A and B make dots on the side of the paper facing down, and magnet rack C and D makes the dots on the side facing up.

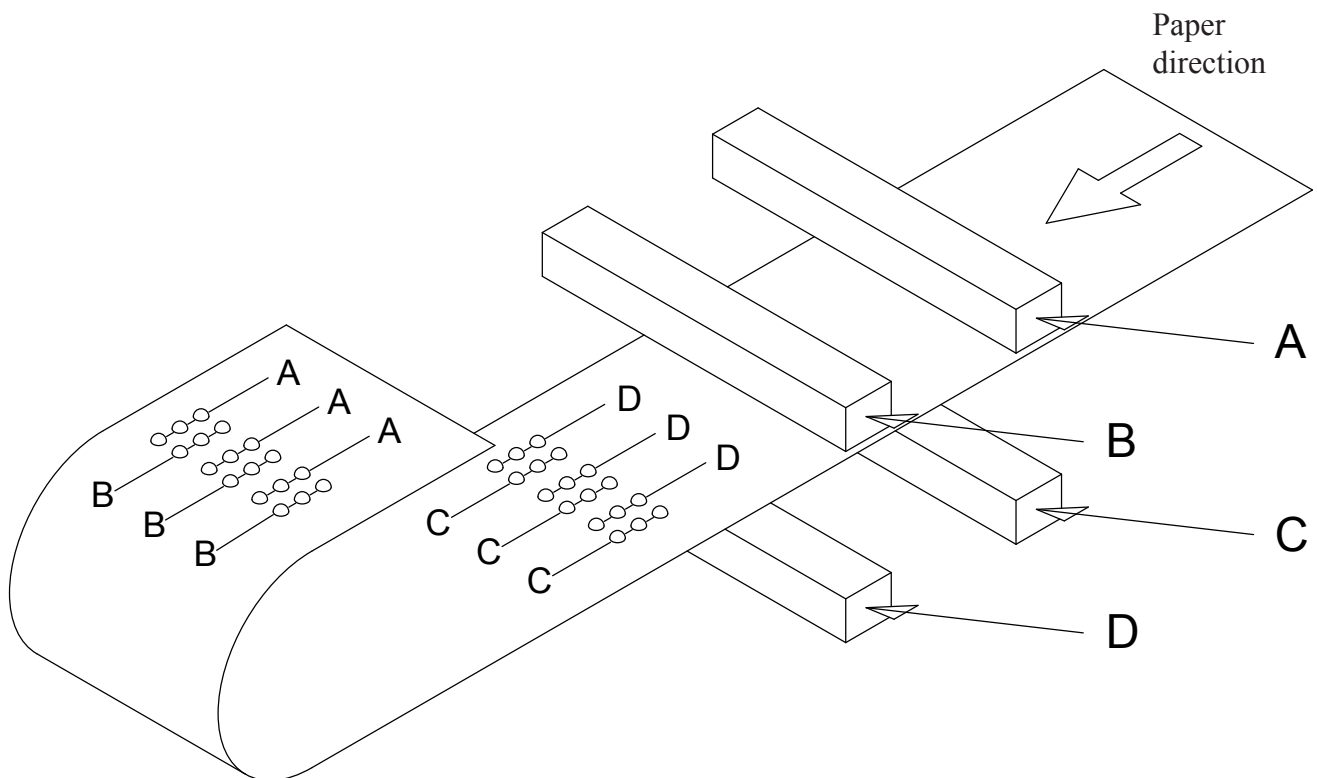

The figure below is a “theoretical” figure showing the parts inside the printing mechanism. The printer has been “sliced” to show more detailed of how it is constructed.

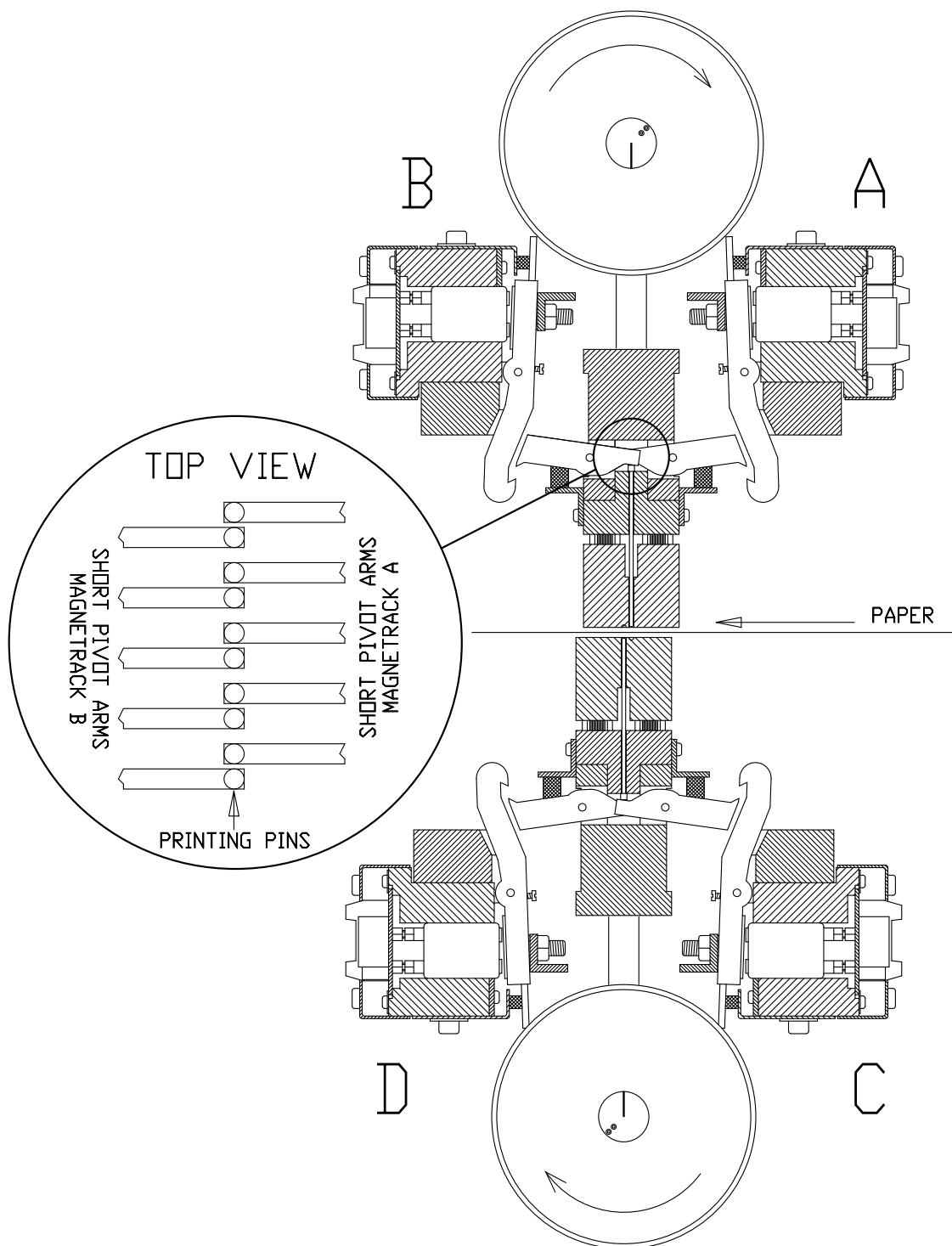

Please see the figure on the previous page.

The two shafts, one at the top and one at the bottom, are rotating synchronized. On each shaft there are eccentrics that are pushing the beams and papershoes up and down. This movement is used both to hold the paper and to make the dots. A row of dots is printed for each revolution of the shafts. The shafts must rotate three times to form a complete row of characters.

Please see figure below:

○ ○ ○ ○ ○ ○ ○ ○ First revolution

○ ○ ○ ○ ○ ○ ○ ○
○ ○ ○ ○ ○ ○ ○ ○ Second revolution

○ ○ ○ ○ ○ ○ ○ ○
○ ○ ○ ○ ○ ○ ○ ○
○ ○ ○ ○ ○ ○ ○ ○ Third revolution

To be able to print interpoint (where both sides of paper are printed simultaneously), the back page is offset a little to the right and a little down to fit in between the dots on the front page.

Please see figure below:

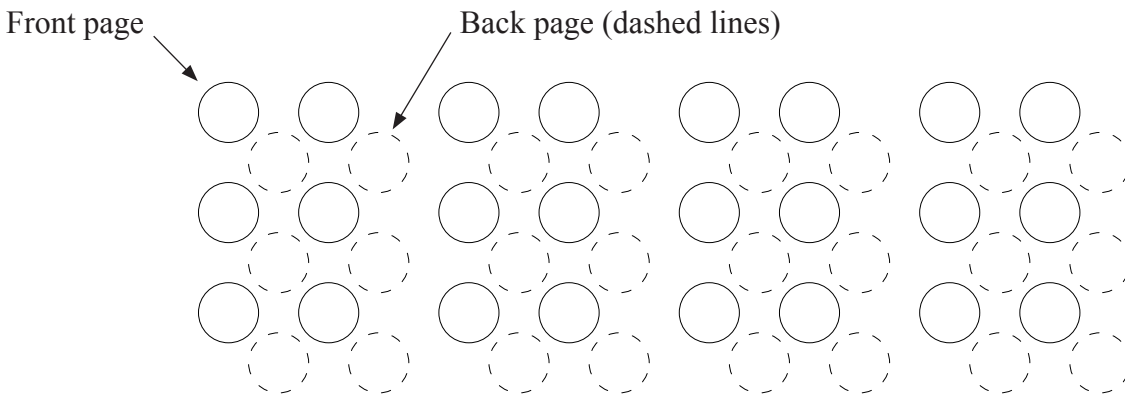

Dimensions on the 6 and 8 dot Braille cell, measured in mm.

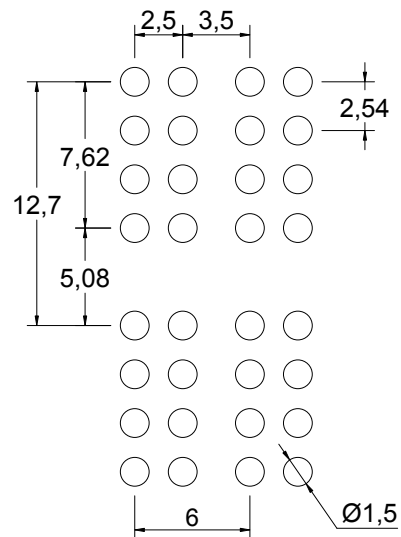
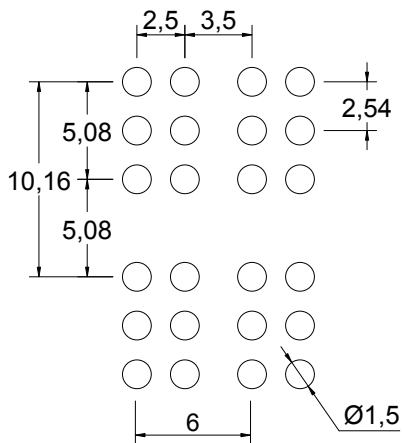

The drawing on this page is meant to help to understand the basic principle of how the dots are printed. Please also see the drawings on the next page.

The parts in the upper left of this drawing is one of the magnet racks. The parts in the lower right, are the beam and paper shoes. The magnet racks itself do not move, but the beams and the papershoes are moving up and down for every revolution of the eccentric shafts.

Inside each magnet rack there are 42 electrical magnets. The magnets are controlling the long pivot arms.

When a dot is going to be printed, the magnet is engaged, and the long pivot arm will be drawn against the magnet poles.

At the same time, the beam and the paper shoe will start to move downwards, and the short pivot arm will catch the hook of the long pivot arm. The beam will continue to travel downwards, and will force the printing pin into the paper.

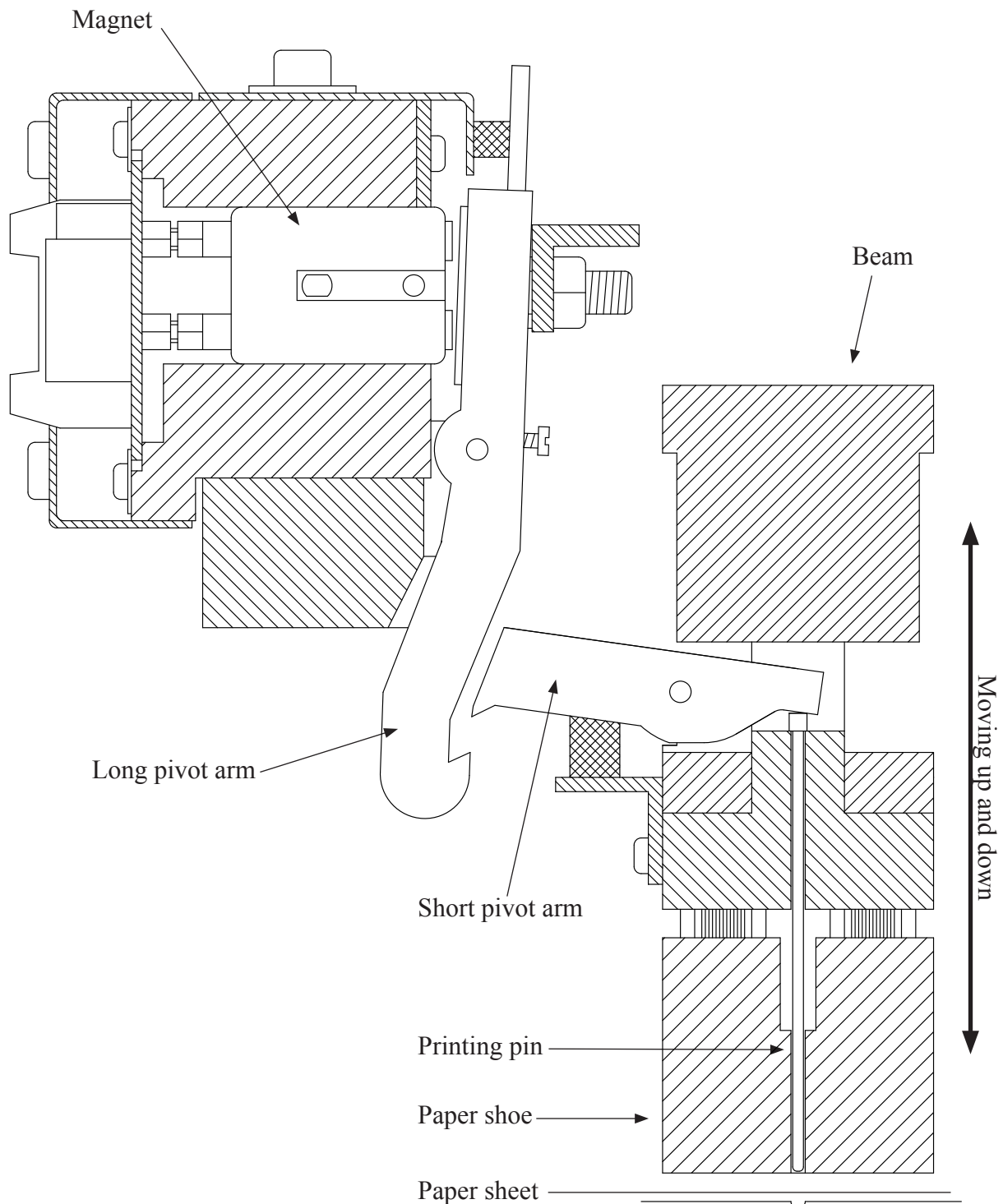

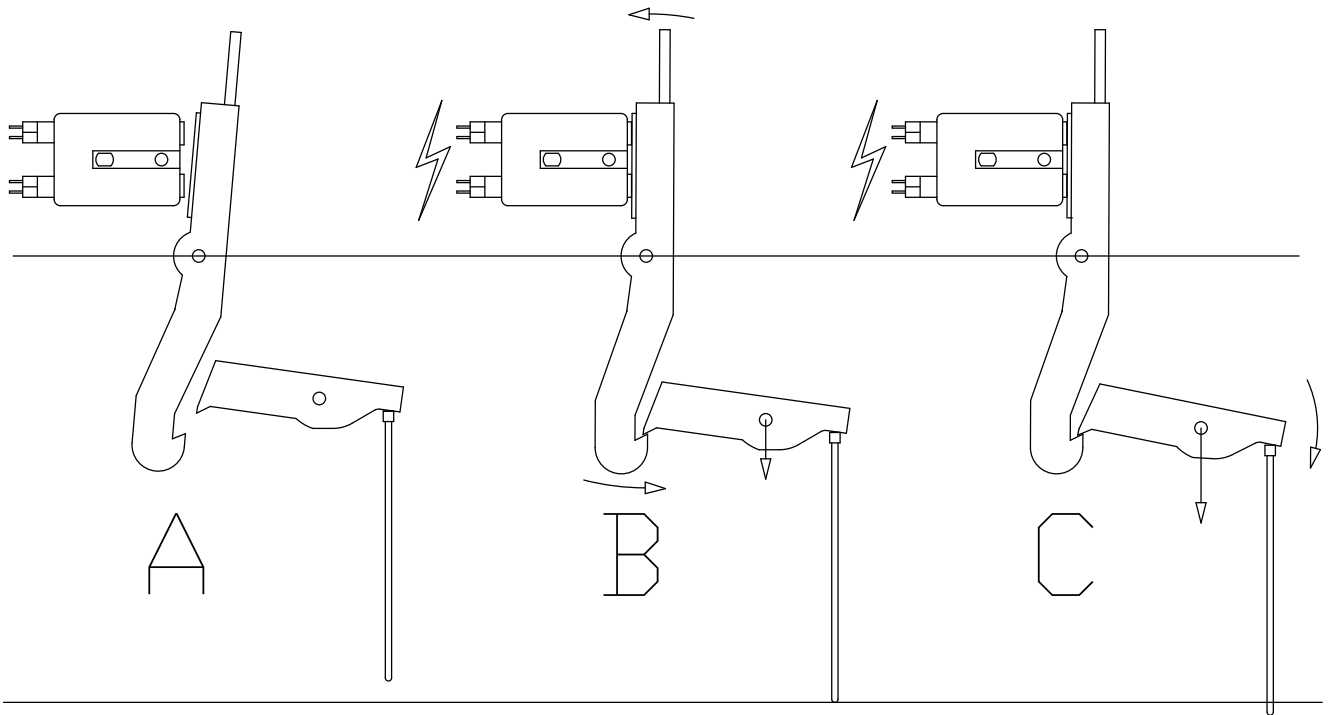
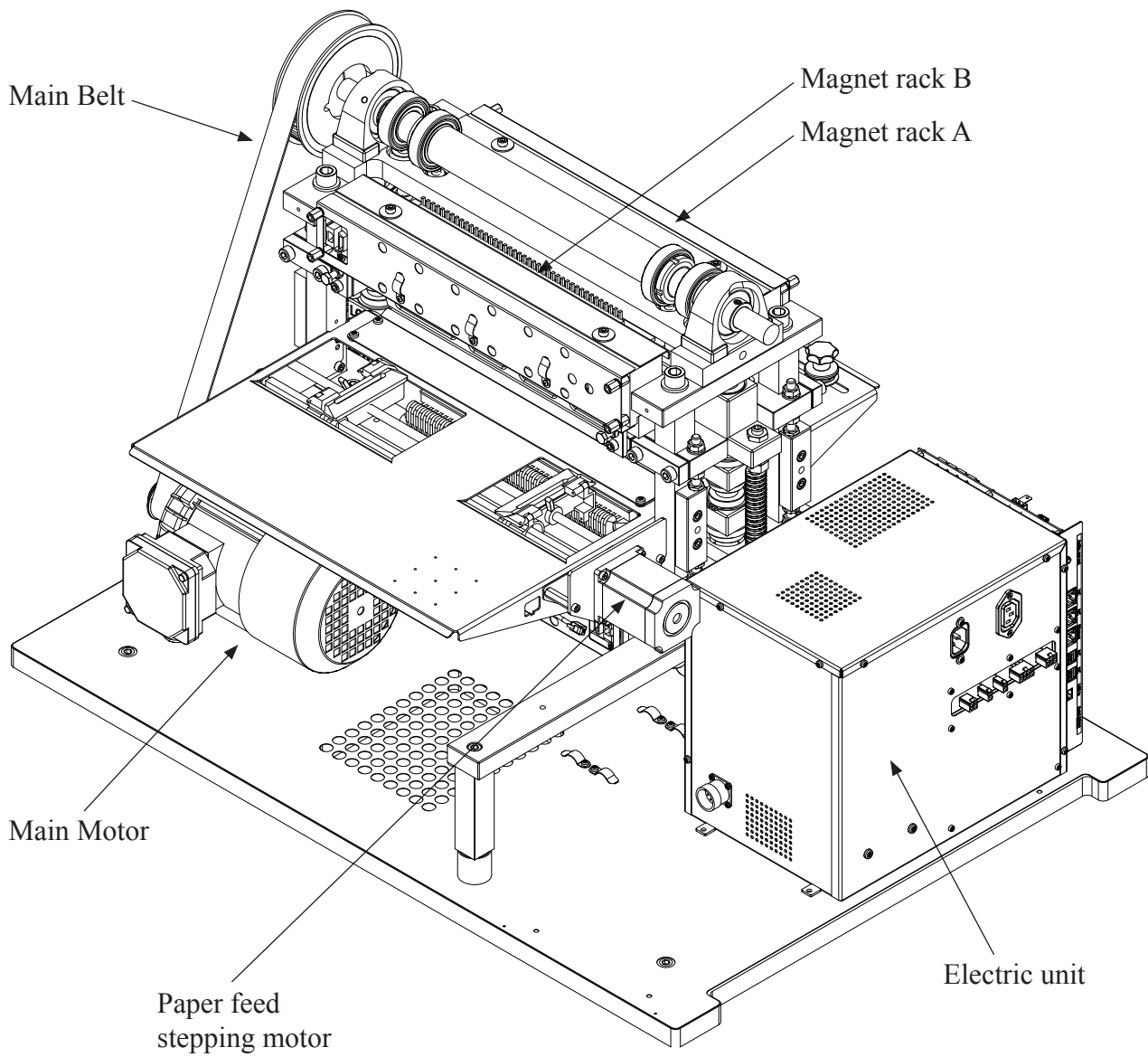

Figure A
Shows the position on the pivot arm when the printer is not printing, and the magnet is not engaged.

Figure B
Now the magnet is engaged, and the long pivot arm has been drawn against the magnet. The short pivot arm is moving down towards the hook on the long pivot arm.

Figure C
The long pivot arm's hook catch the short pivot arm. When the short pivot arm moves further down, the printing pin will be forced down into the paper and make a dot.

General overview



4.2 Troubleshooting, incorrect Braille.

If any errors have been found in some of the characters in the printed text during proofreading, the first thing to do is:

Check the characters in the text-file in the computer to find out if the error could come from the text-file and not from the printer.

If your text-file is OK, the problem is caused by the printer.

On earlier models of Braillo printers, this could be caused by either a electrical problem or a mechanical problem. But on this model of printer, there is integrated a self-diagnostic system that is checking the magnets continuously during printing, and this will trigger an alarm if it detects some electrical problems with the magnets. So, the missing dots found here are probably caused by some faulty mechanical parts or it could be dirt clogging the moving mechanisms.

Inside the printer there are four identical magnet racks, named from A to D. Each magnet rack contains 42 printing mechanisms. There are totally 168 printing mechanisms to choose from when the error search begins. See chapter 4.1, "Printing principle".

If the printer has been printing a lot (a lot could be after a year, or after 1000 printing hours, depending on what comes first) errors in the characters could occur. If this happens, it could just be that the printer needs regular maintenance. See chapter 4.6 "Magnet rack - Cleaning", and chapter 4.21 "Maintenance".

As a start, you should run the built-in Test Print. Depending on what kind of errors you have, you should use different tests.

The essential thing at this stage is to find which magnet rack(s) is causing the trouble.

If there is missing dot(s), use the X-pattern to detect which magnet rack(s) is missing the dot(s).

If there are too many dots, use the full cell lines, or the test pattern on test print no. 4, and the extra dot(s) will appear in the space between the lines.

However, the best test is ordinary text, if a proofreader is available. To locate the faulty magnet rack(s), see figures in chapter 4.1 "Printing principle".

There are several methods to make experiments to confirm that you have found the correct magnet rack(s). One good method is to disconnect the rest of the magnet racks, and see if the printer still have problems.

To determine if a problem is electrical or mechanical.

See if the suspected pivot arm is moving like the rest of the pivot arms on the magnet rack. If it does move, but still does not make dots, then it is probably a mechanical problem. If it does not move and it is possible to pull the suspected long pivot arm with your finger during embossing and then dots starts to appear. Then it most likely is caused by some problems in the electric circuits.

If one magnet rack is missing all the dots all the time, it could be because of a blown fuse. On the back of the magnet racks there is a red light that is indicating that the magnet rack has power. If this light is dark, check the fuse for the magnet rack.

See chapter 6.2 "Electric unit - Overview" for more details.

Possible reasons for errors:

See figures on the next page.

If a dot from a certain printing pin is missing regularly, the reason might be one of the following:

1. Defective magnet (The self-diagnostic system will find this one first).
2. Broken short pivot arm.
3. The long pivot arm cannot move because of dirt.
4. The printing pin is stuck because of dirt, causing the short pivot arm to miss the long pivot arm.
5. Errors in the magnet rack board.

If dots from several printing pins are missing now and then, the reason might be one of the following:

1. The sponge list is pushing too hard on the long pivot arm.
2. The gap between the two pivot arms is too large.
3. The support list has become sticky on the side against the long pivot arms, and the long pivot arm does not move properly.
4. The sponge list on the short pivot arm is so worn/compressed so that it will not give enough tension on the pivot arm.

If there are too many dots on the paper, the reason might be one of the following:

1. The sponge list is not pressing enough against the long pivot arm.
2. The gap between the two pivot arms is too small.
3. The magnet poles have become sticky, and this causes the pivot arms to stick to the magnet.
4. The long pivot arm (3) does not move properly.

Control:

To be sure that you have found the right mechanism after the troubleshooting, you can do the following test: Pull carefully the suspected long pivot arm against the magnet with your finger.

Note! Please be careful to avoid getting in contact (e.g. clothes, hair, beard, jewelry or any part of the body) with any other moving parts of the Printer to prevent personal injuries!

At the same time, run a test print. The mechanism with the finger on, will make a column of dots downwards the sheet until you take the finger away. By doing this you can see if this column of dots is situated on the same place (and same side!) on the sheet as the error is.

Observe that the same printing mechanism (magnet, long pivot arm, short pivot arm and printing pin) makes all the dots in a column downwards the page.

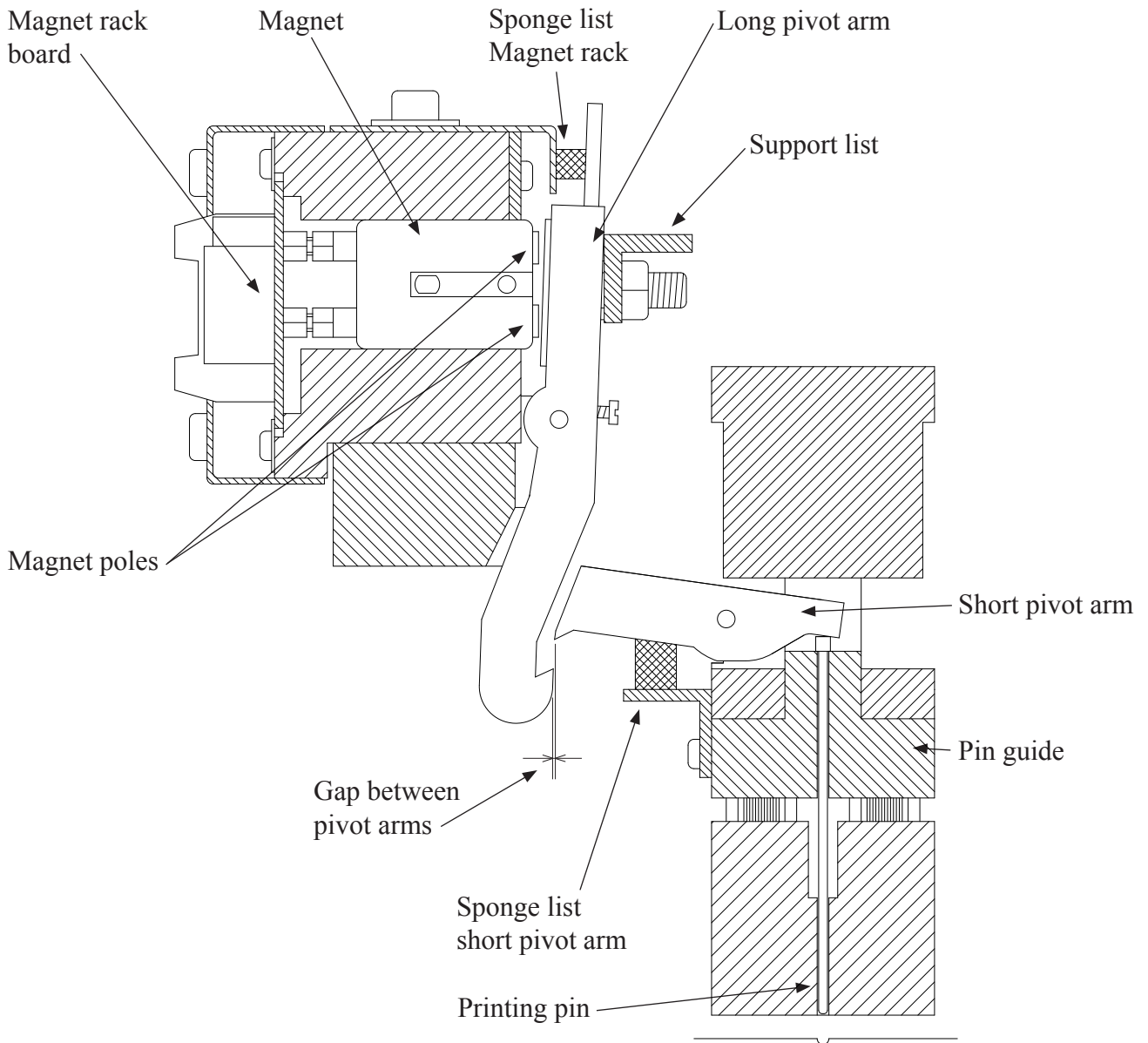

4.3 Magnet rack - Removal

Please see figures below:

Disconnect the cables for the magnet rack.
 Remove the magnet rack by unscrewing the four screws shown in the figure.
 Magnet racks A, B and C are quite easy to reach, but to remove magnet rack D, it is often best to first remove the paper feed tractor.
 Please see chapter 4.17 "Paper feed assembly - Removing" for a description on how to remove the tractor.

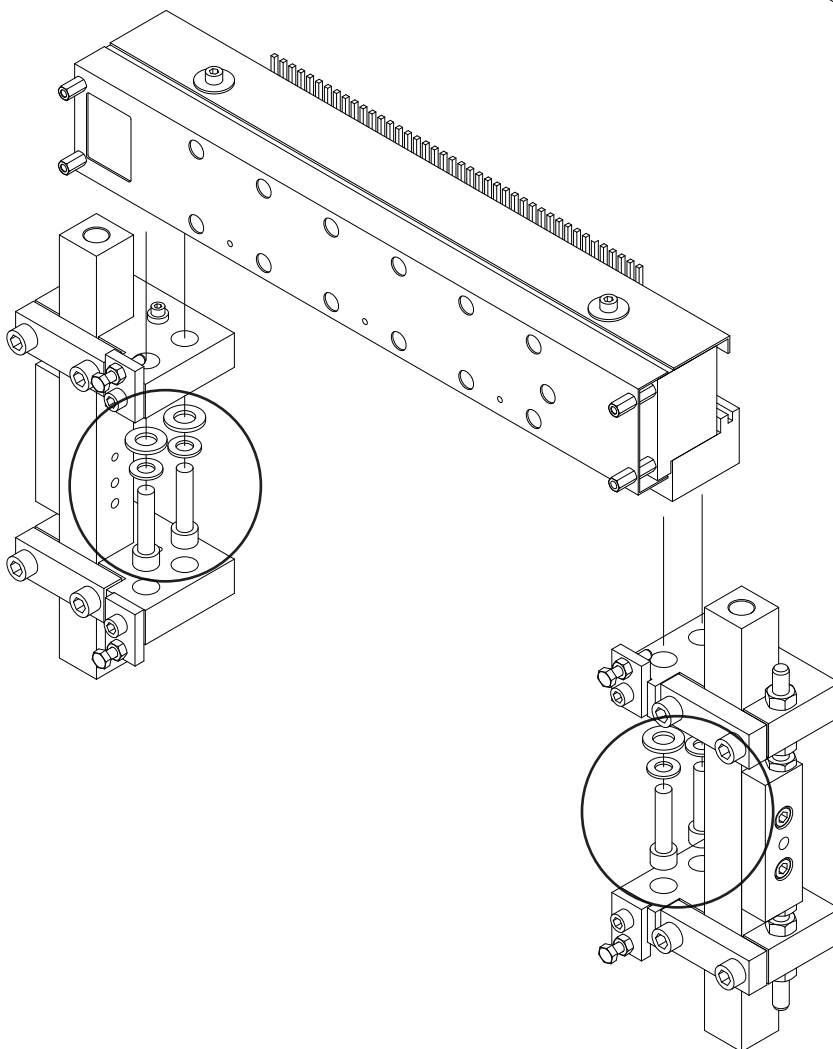
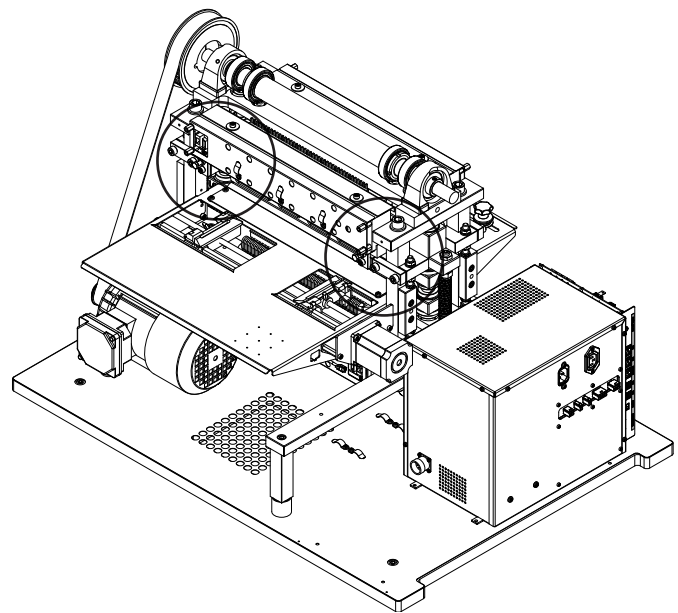

4.4 Magnet rack - Disassembly, step by step.

There are two main reasons for disassembling the magnet rack. It could be to replace some parts, i.e. a defect magnet, a worn pivot arm, or it could be for regular maintenance.

The magnet racks can be considered as the parts of the printer that will have the greatest influence on the dot quality, so it is very important to know how to deal with them.

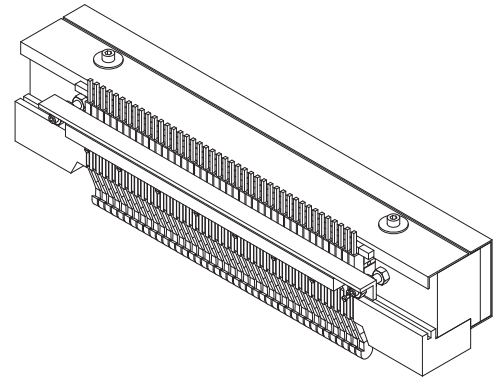

Take the magnet rack out of the printer like described in chapter 4.3 “Magnet rack - Removal”. Next, follow the instructions below.

Step 1. Remove the two bolts holding the sponge list, and then remove the sponge list.

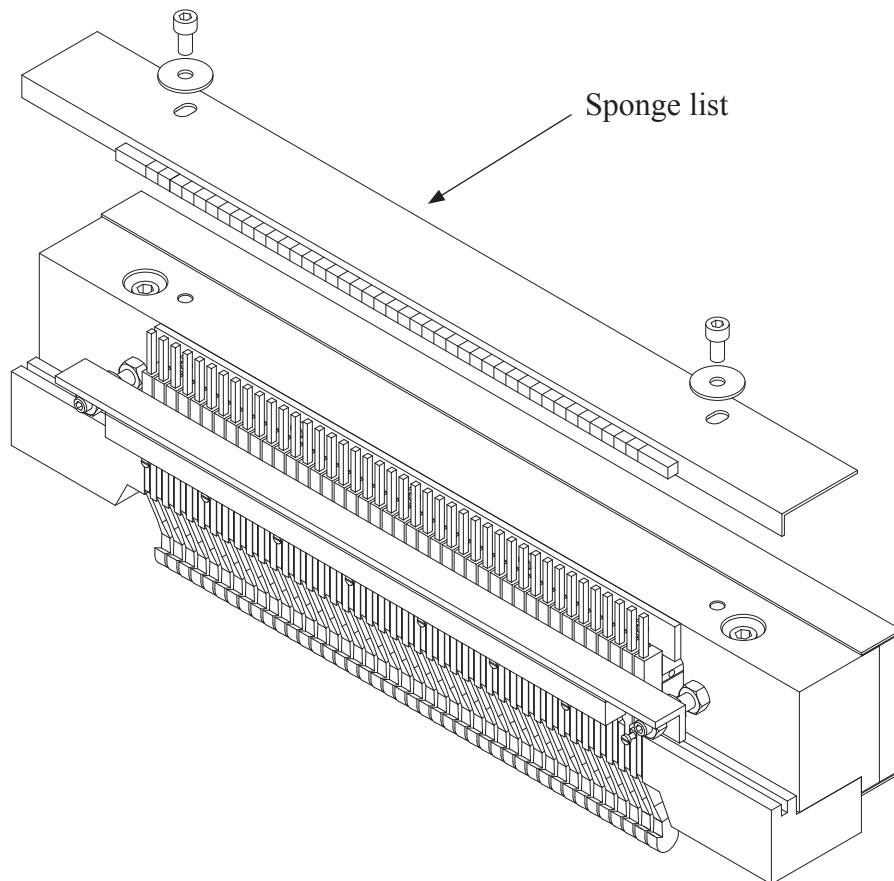

Step 2. Remove the two nuts holding the support list, and then remove the support list.

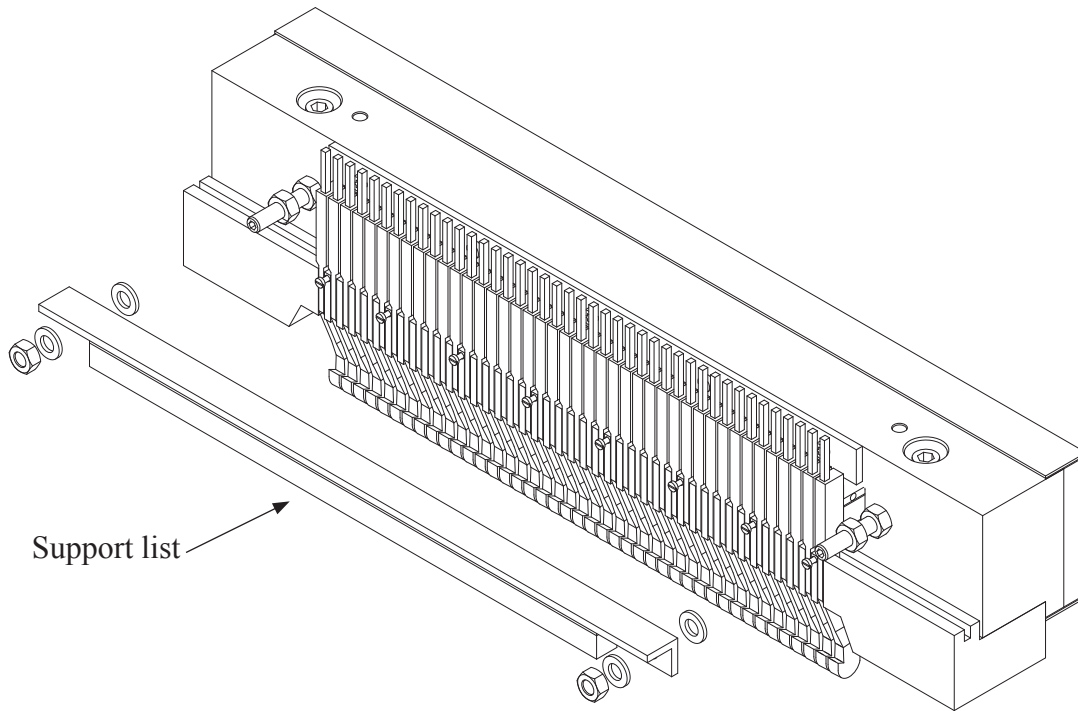

Step 3.

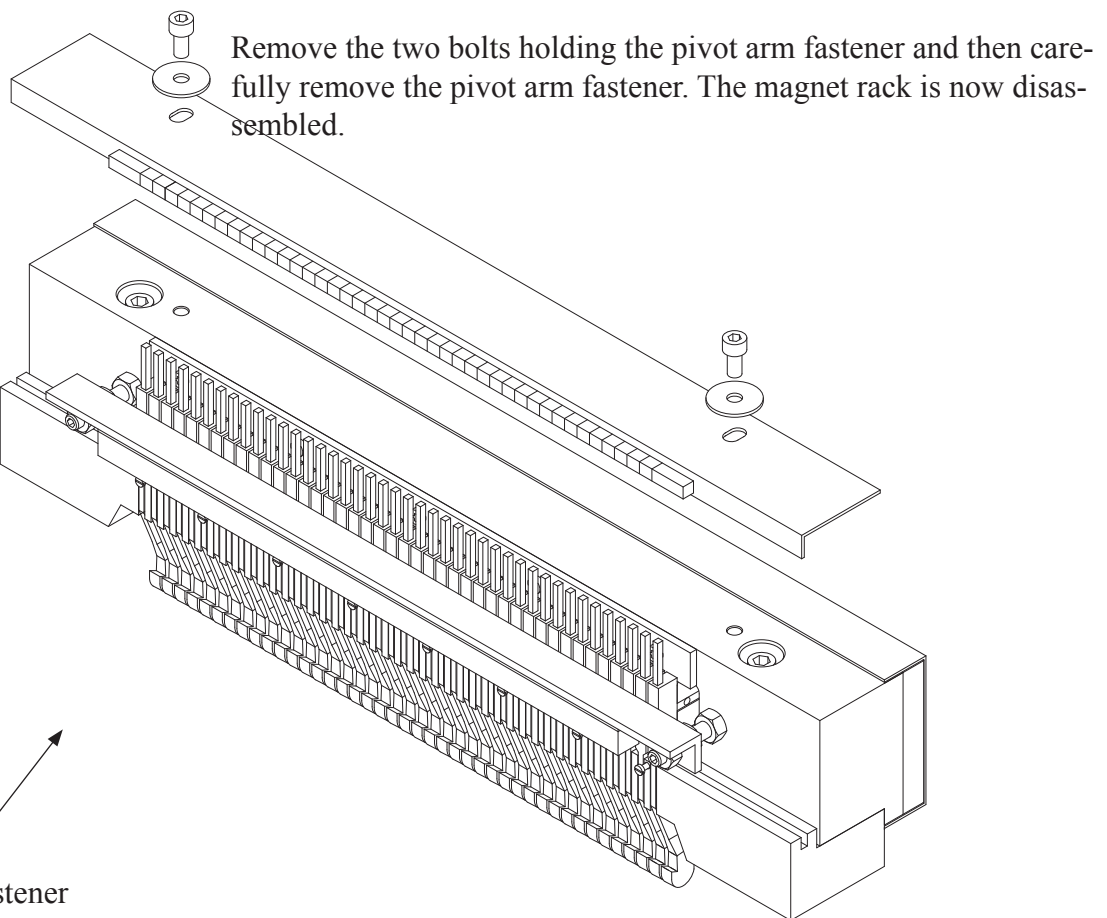

4.5 Magnet - Replacement

Please observe that the numbering on the magnets in a magnet rack, always starts at “one” at the end where the connections are. (It does not refer to dot number, character number or column number!).

Disassemble the magnet rack like described in chapter 4.4 “Magnet rack - Disassembly, step by step”. Next, follow the instructions below.

Step 1. Remove the five screws holding the list, and the list.

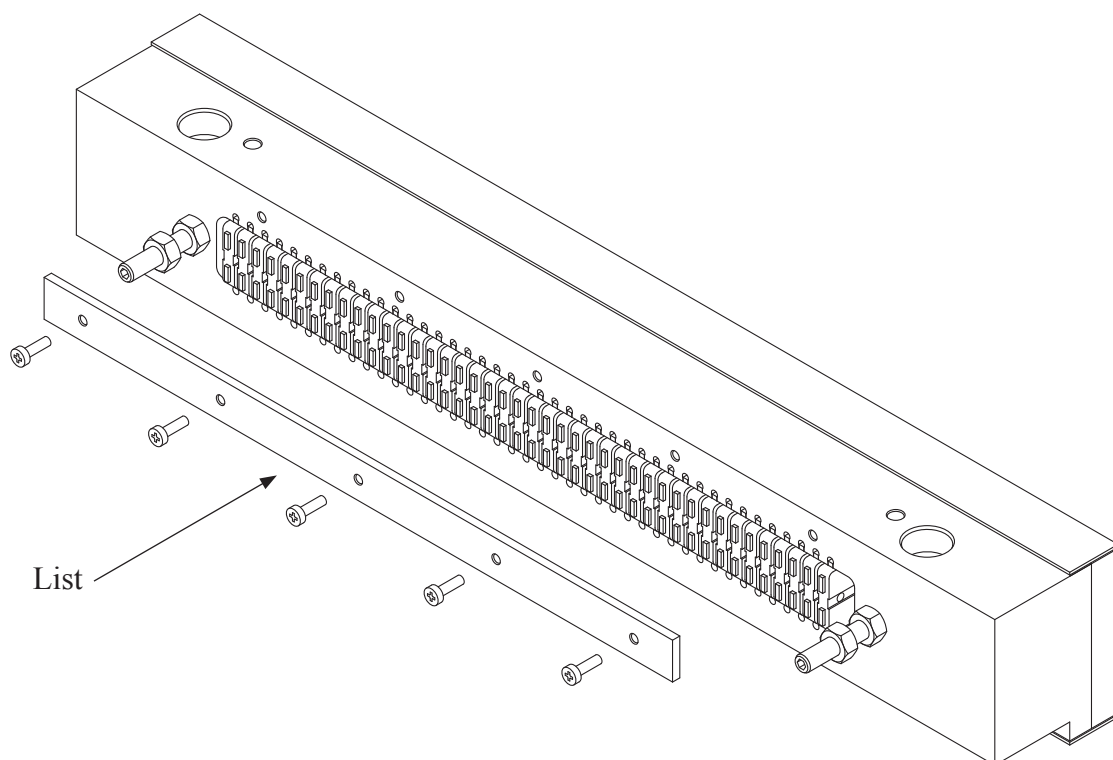

Step 2. Pull out the defect magnet with, e.g. a narrow pair of “needle nose” pliers.

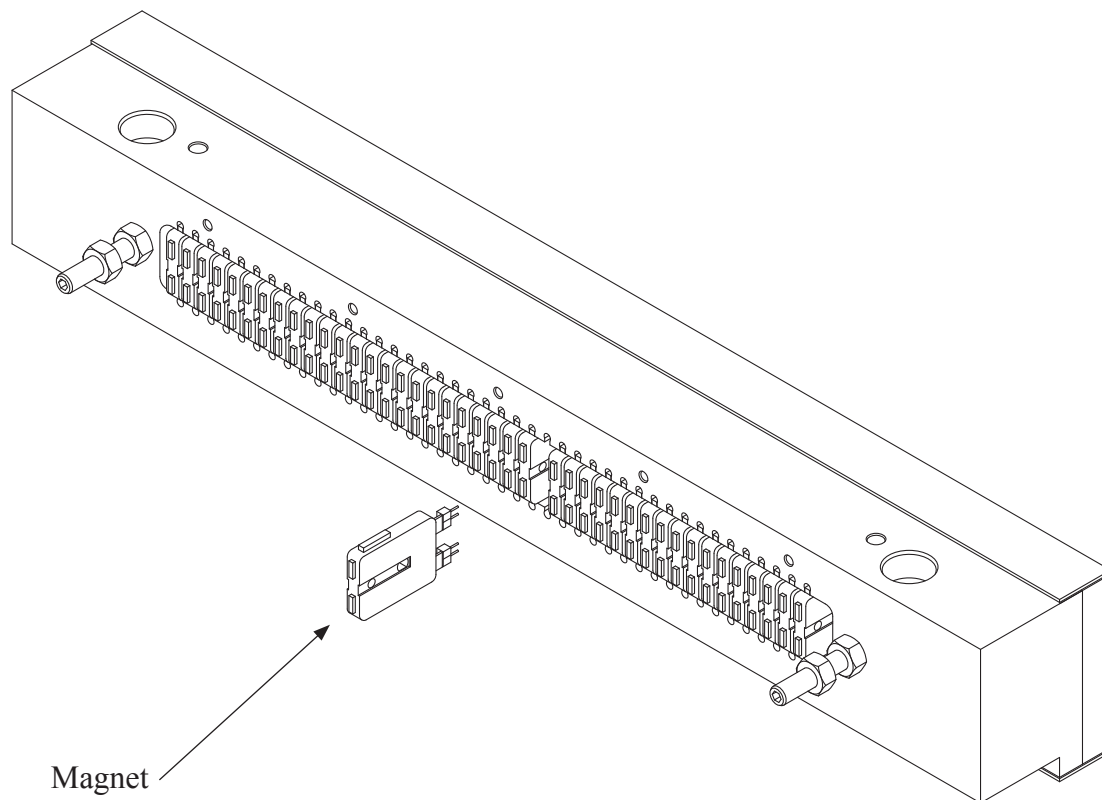

Step 3. Check the magnets internal resistance if you have an ohm-meter available. The resistance should be from 185 ohm up to 240 ohm. Any value outside this range indicates a defective magnet.

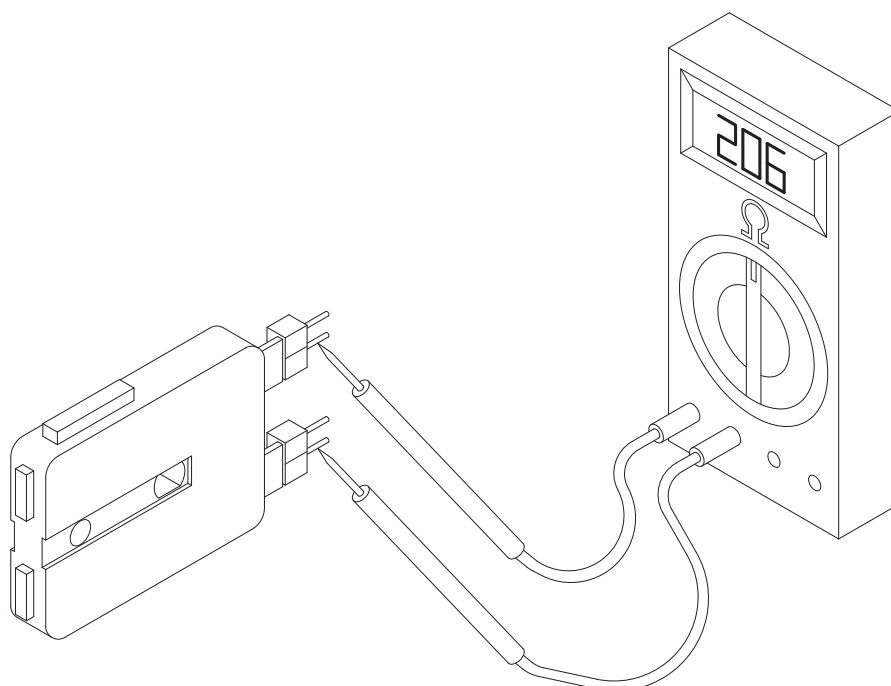

Step 4. Replace the defective magnet with a new magnet in its place. Note the spikes on one of the sides on the magnet. These spikes must be oriented the same direction as the rest of the spikes in the magnet rack.

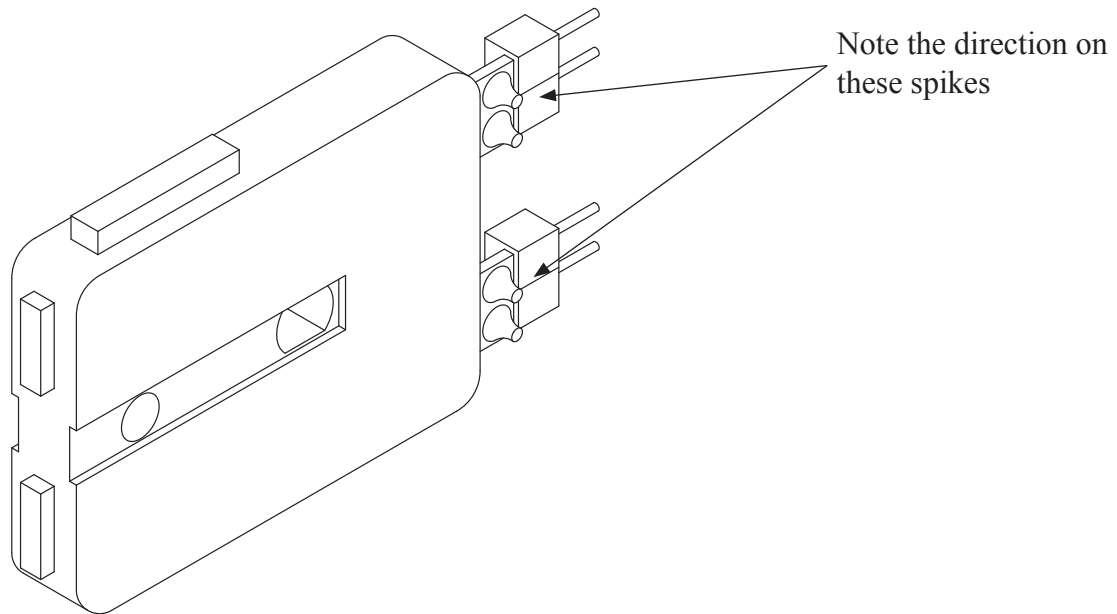

4.6 Magnet rack - Cleaning

Remove the magnet rack as described in chapter 4.3 “Magnet rack - Removal”.

Then disassemble the magnet rack as described in chapter 4.4 “Magnet rack - Disassembly, step by step”.

Now use a damp cloth moistened with cleaning alcohol to wipe off the surfaces as described in the figure below:



Note! Never oil, grease or lubricate any of the moving parts on a magnet rack!
This will only attract paper dust.

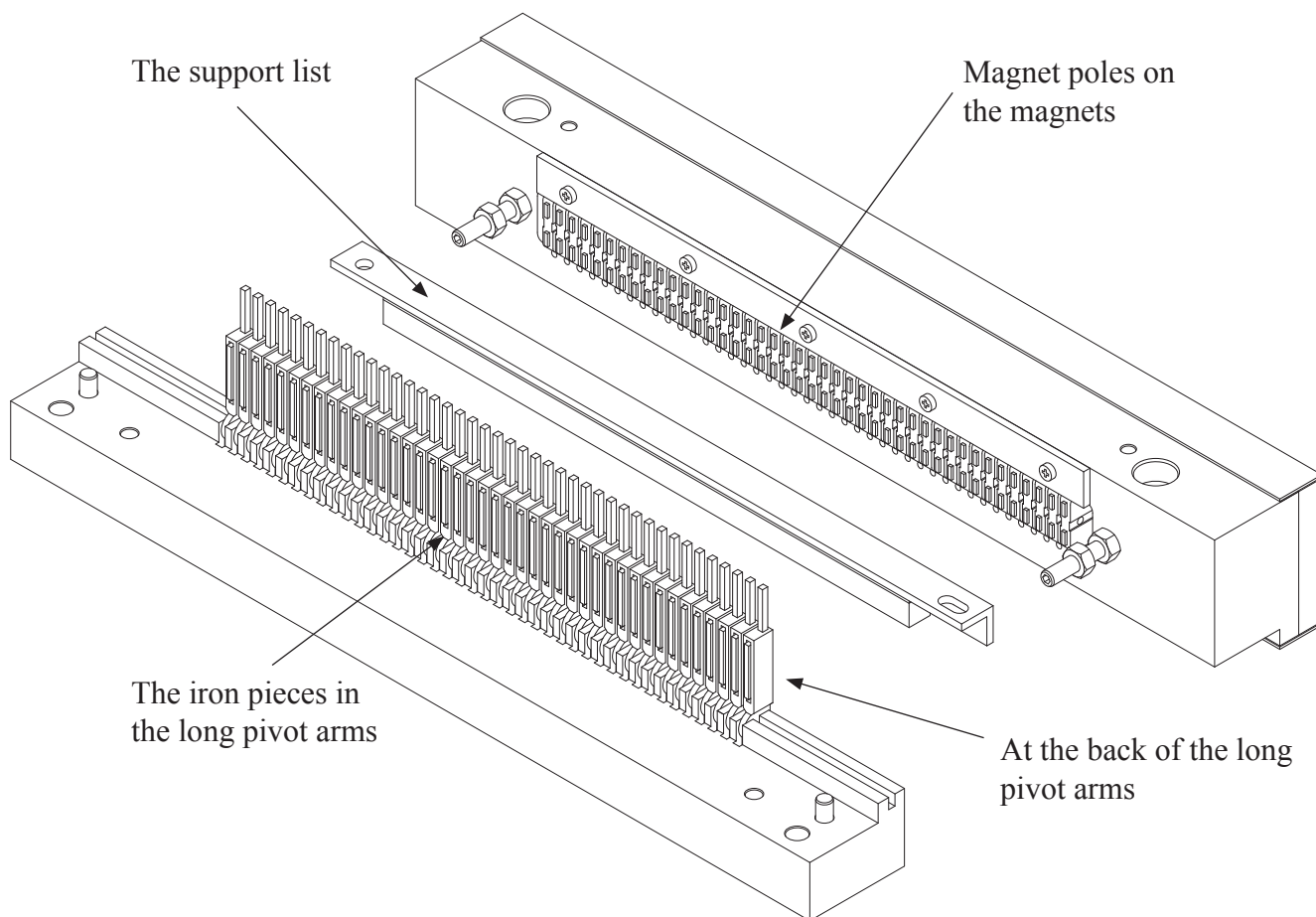

4.7 Magnet Rack - Adjustment

Before replacing the magnet rack in the printer, two adjustments must be checked.

The first is the distance between the support list and the pivot arms. This is the travelling distance for the pivot arm. And it should be adjusted to about 0.8 mm using a feeler gauge. Adjust the nuts on both ends of the magnet rack.

If the 0.8 mm feeler gauge goes in, and the 0.9 mm feeler gauge does not, consider the adjustment OK.

Make sure that the nuts are tight when you are done!

Please see figure below:

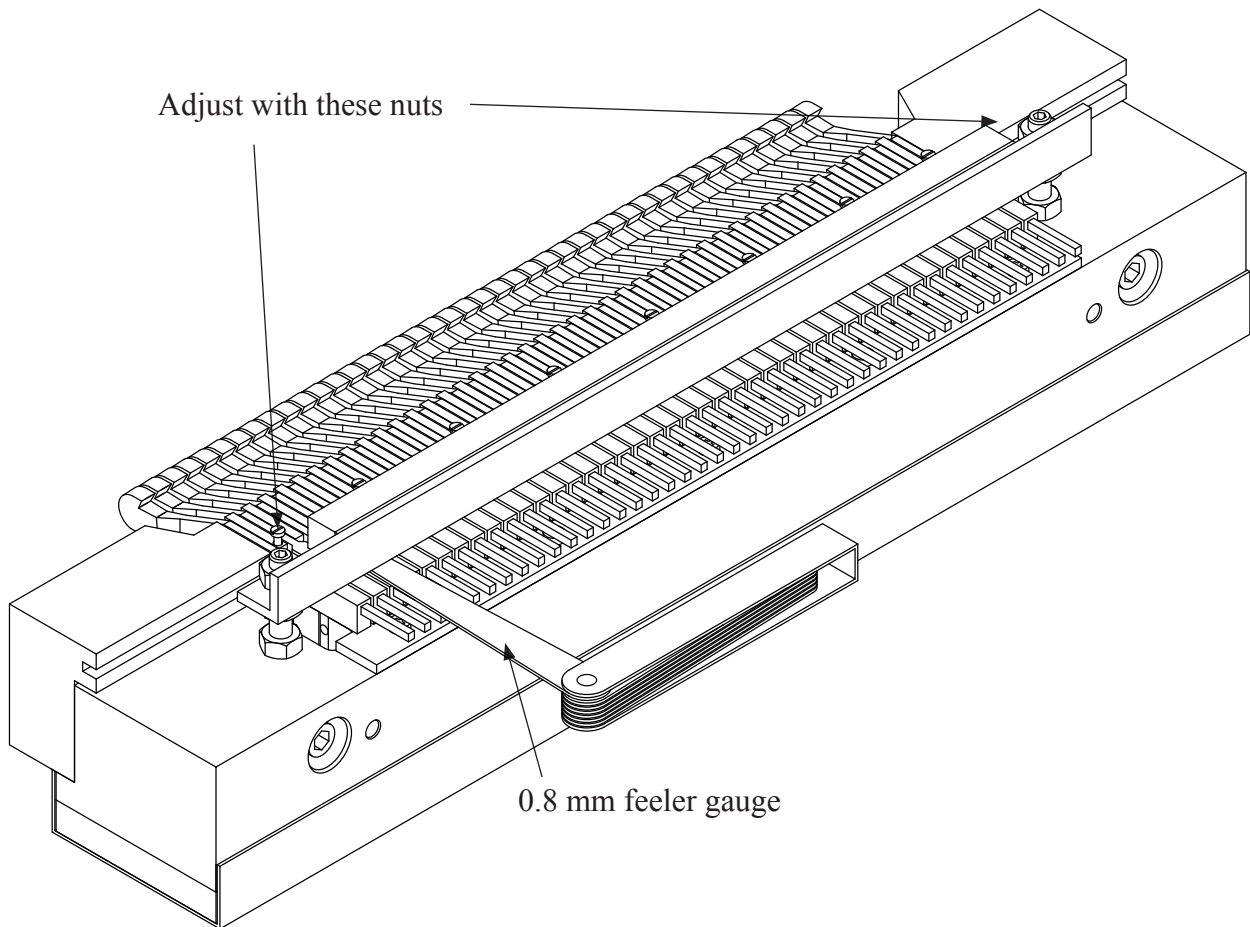

The second adjustment is the pressure the sponge list makes against the pivot arms. The sponge list works as a return spring for the pivot arms. The correct adjustment is when the sponge list is slightly pressing against the pivot arms, but the pivot arms can still move freely.

Please see figure below:

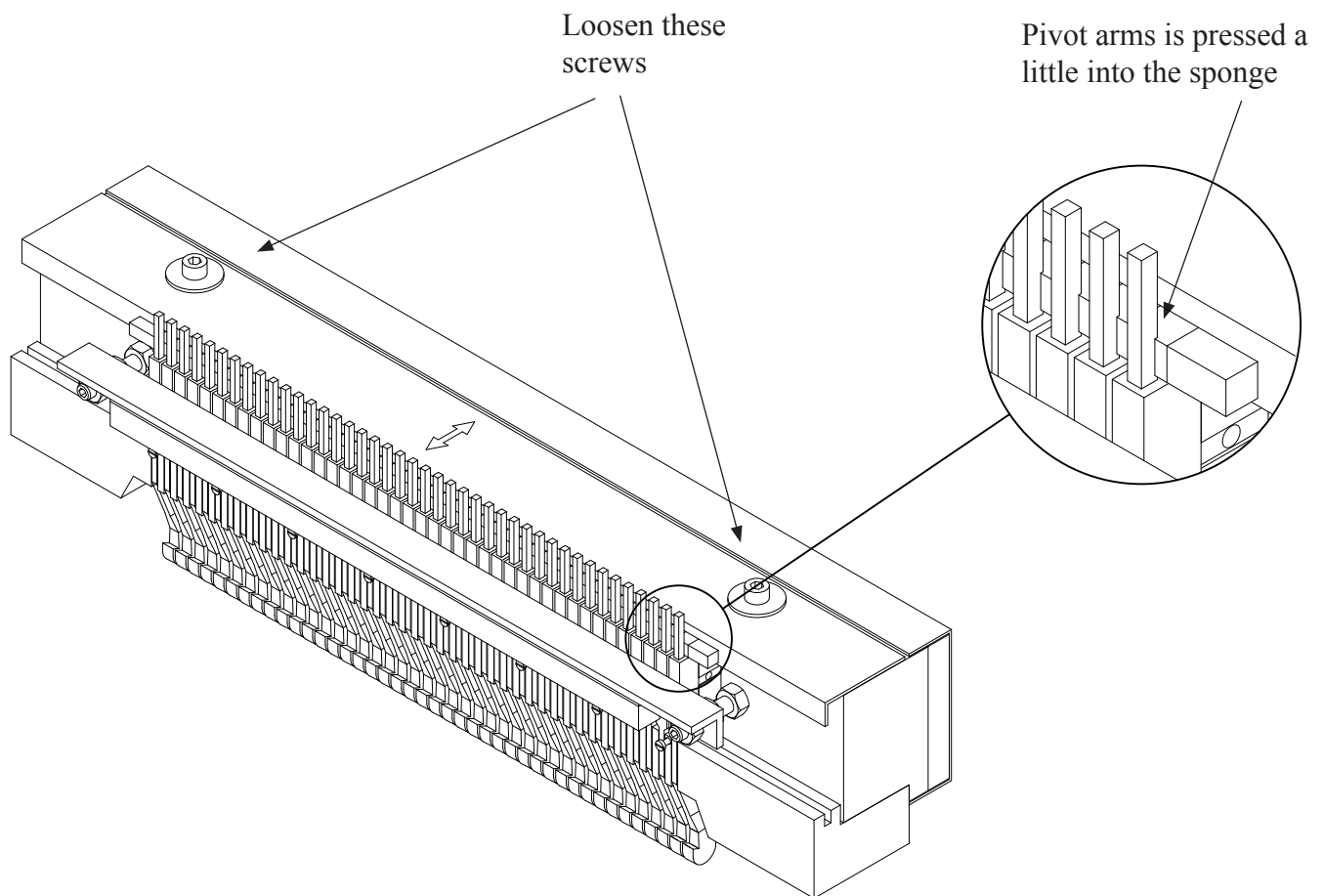

4.8 Magnet rack - Refitting and adjusting

Please see figure below:

Before putting the magnet rack back on the printer, make sure that the magnet rack itself is adjusted as described in the previous chapter.

When replacing the magnet rack in the printer:

Put in the four fastening screws, but do not tighten them. Slide the magnet rack horizontally away from the printer, so that the magnet rack is touching the horizontal adjustment screws. This will ensure that the magnet rack is in exactly the same position as before it was taken off the printer.

See next chapter regarding correct adjustment of the magnet racks.

Note! All explanations refer to one magnet rack, but these adjustments must be done on all four magnet racks.

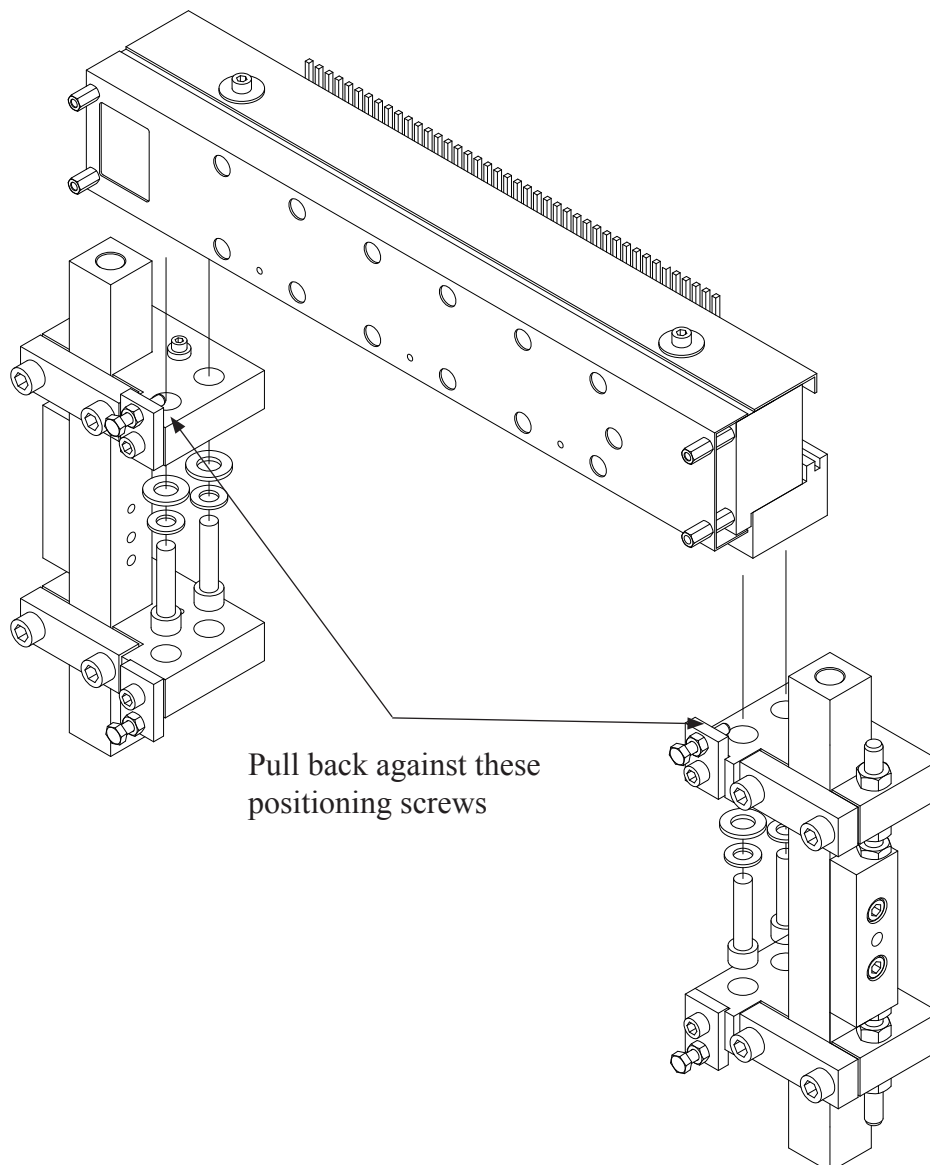

The magnet rack must be adjusted in two directions, horizontal and vertical.

The horizontal adjustment is done first. This adjustment positions the magnet rack correctly in relation to the short pivot arms. If the printer prints too many or too few dots, the horizontal adjustment could be the problem.

Then the vertical adjustment is done. This adjustment will affect the pressure the pivot arms put on the printing pins. This directly affects the shape of the printed dots.

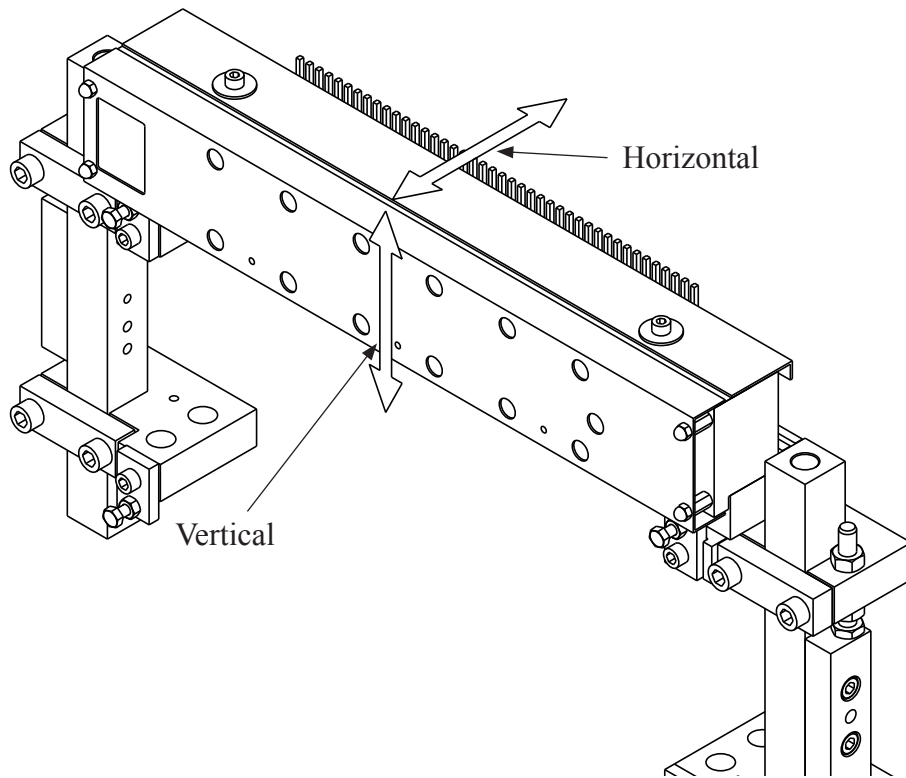

To be able to adjust the magnet rack correctly, it is necessary to put the printer in “printing position”.

This is done by rotating the main belt by hand until the arrows at the ends of the shaft are pointing in the opposite direction of each other.

It is possible to get the mechanism to balance in this place, but you can also lock the shafts with e.g. a self locking wrench (“vice-grip” pliers).

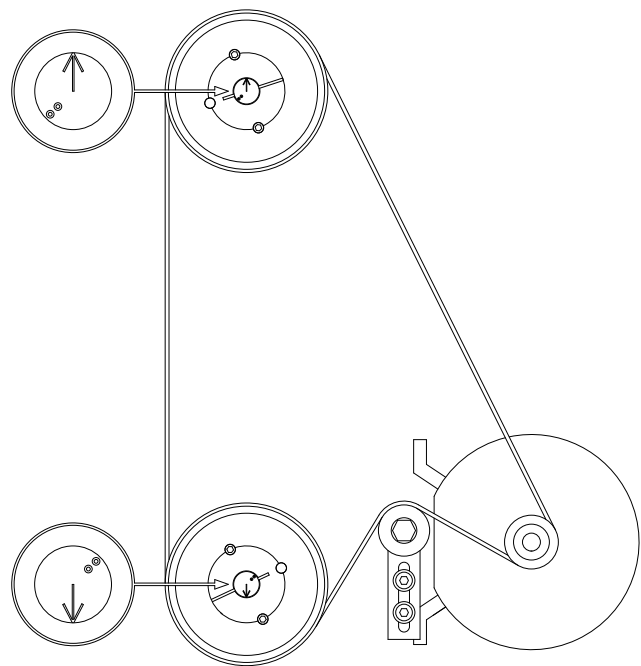

When the arrows at the end of the shafts are pointing in the opposite direction of each other, the short pivot arms will be approximately positioned like in the figure below:

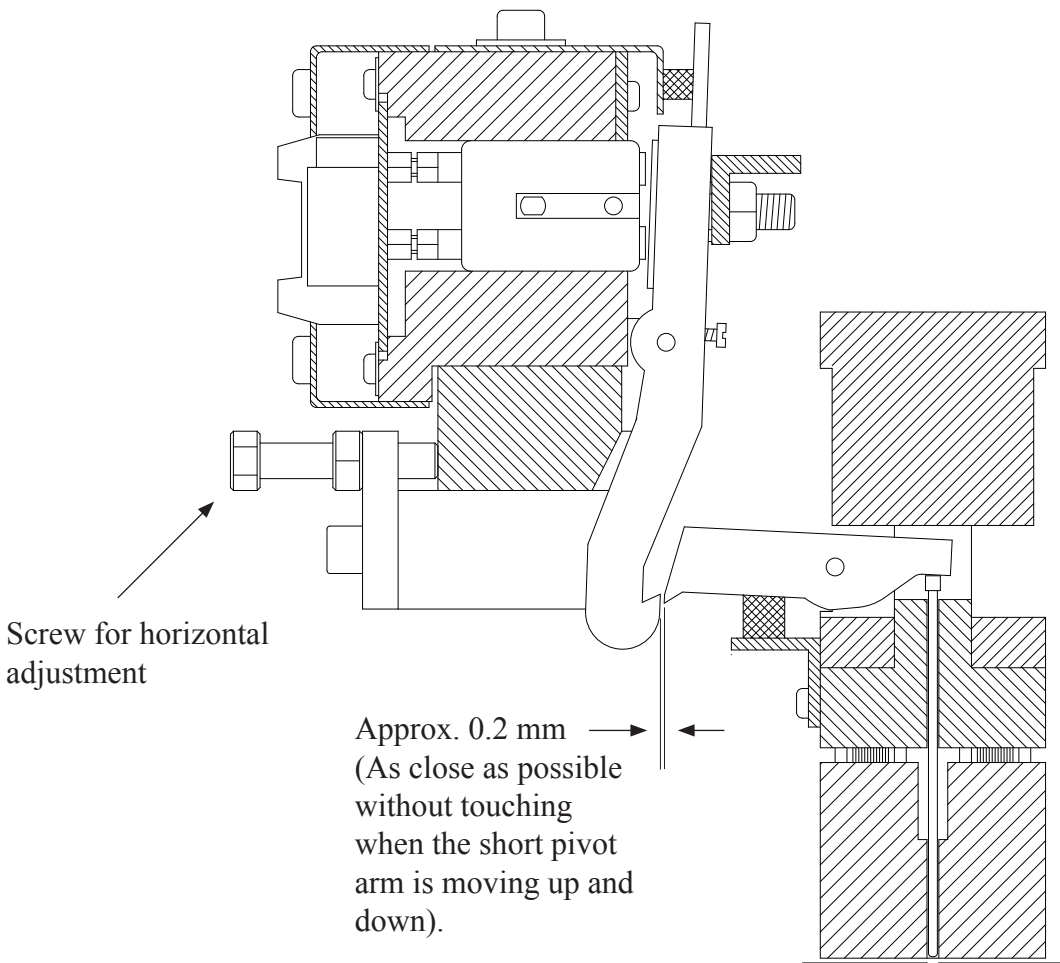

The gap between the long and the short pivot arm should be approximately 0.2 mm. When adjusting this, make sure that the gap is even for all the pivot arms and the same on both ends of the magnet rack.

How to adjust:

Observe that the screw for horizontal adjustment will not pull the magnet rack outwards, they will only push inward.

So the best way of doing this, is to loosen the four fastening bolts holding the magnet rack. Then unscrew the horizontal adjustment screw a little. Now slide the magnet rack outward from the printer, so it touches the horizontal adjustment screws again. Then tighten the four fastening screws just a little so the magnet rack is held firmly in place, but is still able to move. Use the horizontal adjustment screw to move the magnet rack closer to the printer. If this is done in small steps, it is possible to watch the gap getting smaller, and the trick is to stop just before the long pivot arm is touching the short pivot arm.

When the position is correct, tighten the four fastening bolts.

Next is vertical adjustment.

Note! The printer must be in the “printing position” when checking this distance.

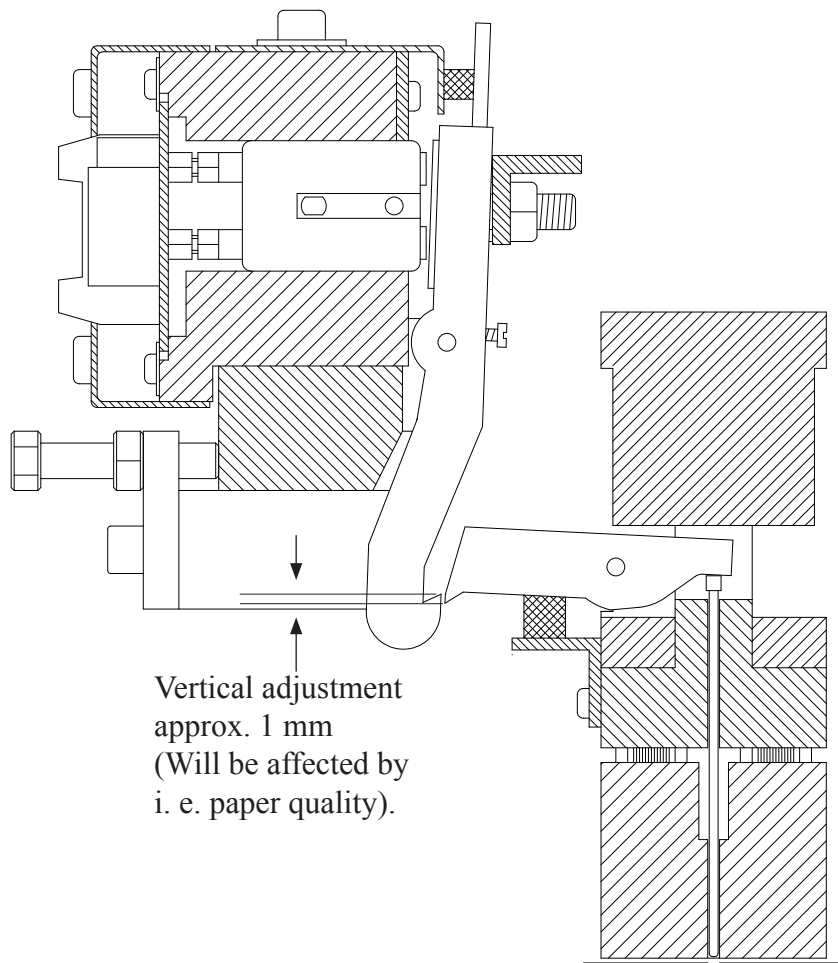

The vertical adjustment of the magnet rack sets the pressure of the printing pins when making dots.

The amount of pressure needed depend on several things. The first (and most important) is the paper quality. The second, is the personal pretences of dot quality.

So the best way to find the correct level of vertical adjustment, is to first decrease the pressure so the dots will be very faded and weak.

Then readjust the pressure up in small steps until the dot quality is satisfactory. By doing this you can make sure that you are running the printer with just enough pressure to make good dots, but not so much pressure that the printer will be worn/damaged.

From our experience we have found that the vertical adjustment should be approximately 1 mm, but if the Braille dots are too weak, you may adjust the magnet rack tighter in small steps (increase the 1 mm distance).

Please see figure on next page:

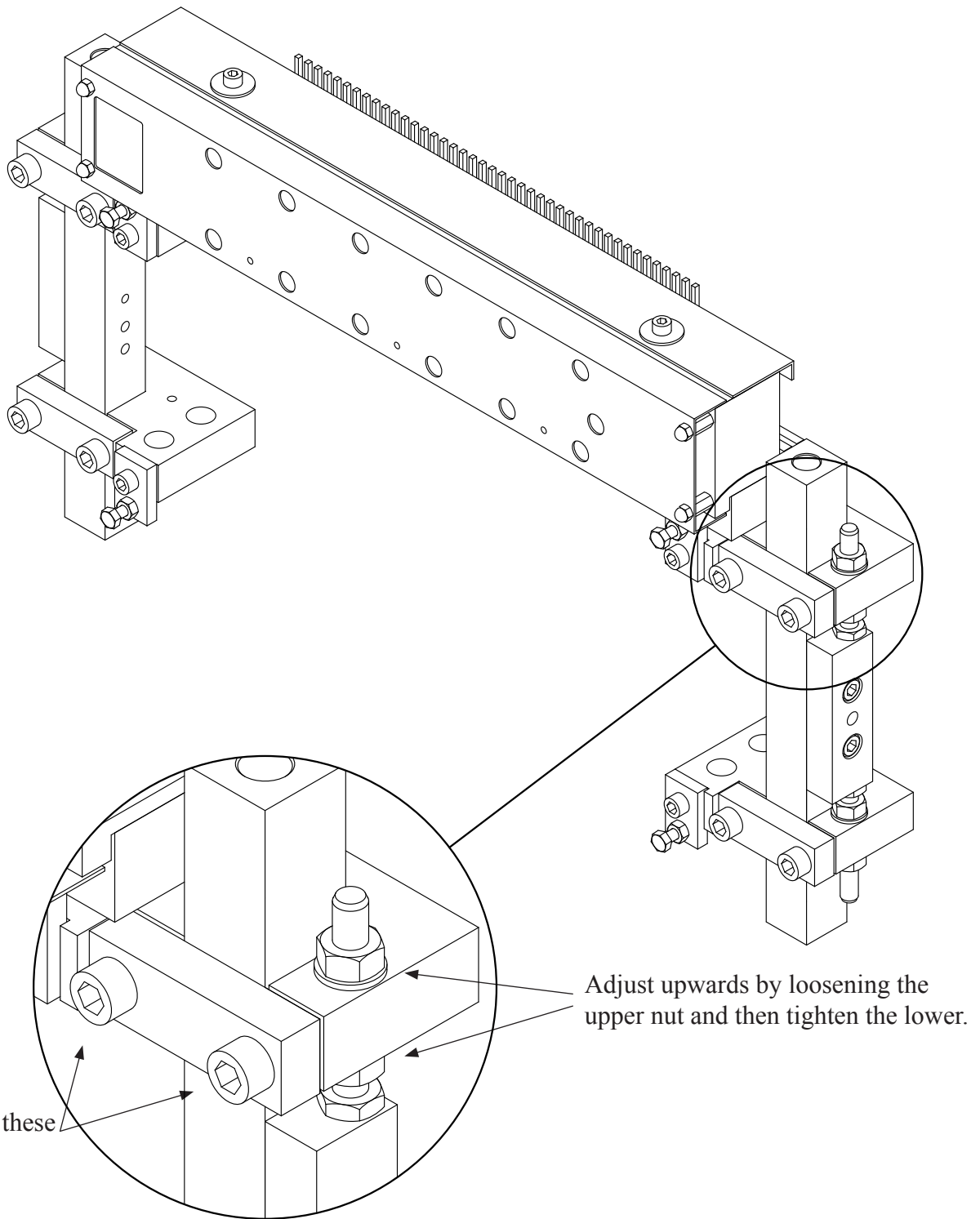

Note! Adjust in small steps, only 1/4 of a revolution at a time. Then test the Braille quality.



Note! When adjusting the magnet racks vertically, observe that magnet rack A and B must be moved upwards to increase the pressure, and magnet rack C and D must be moved downwards to increase the pressure.
 (Moving away from the paper increases pressure).

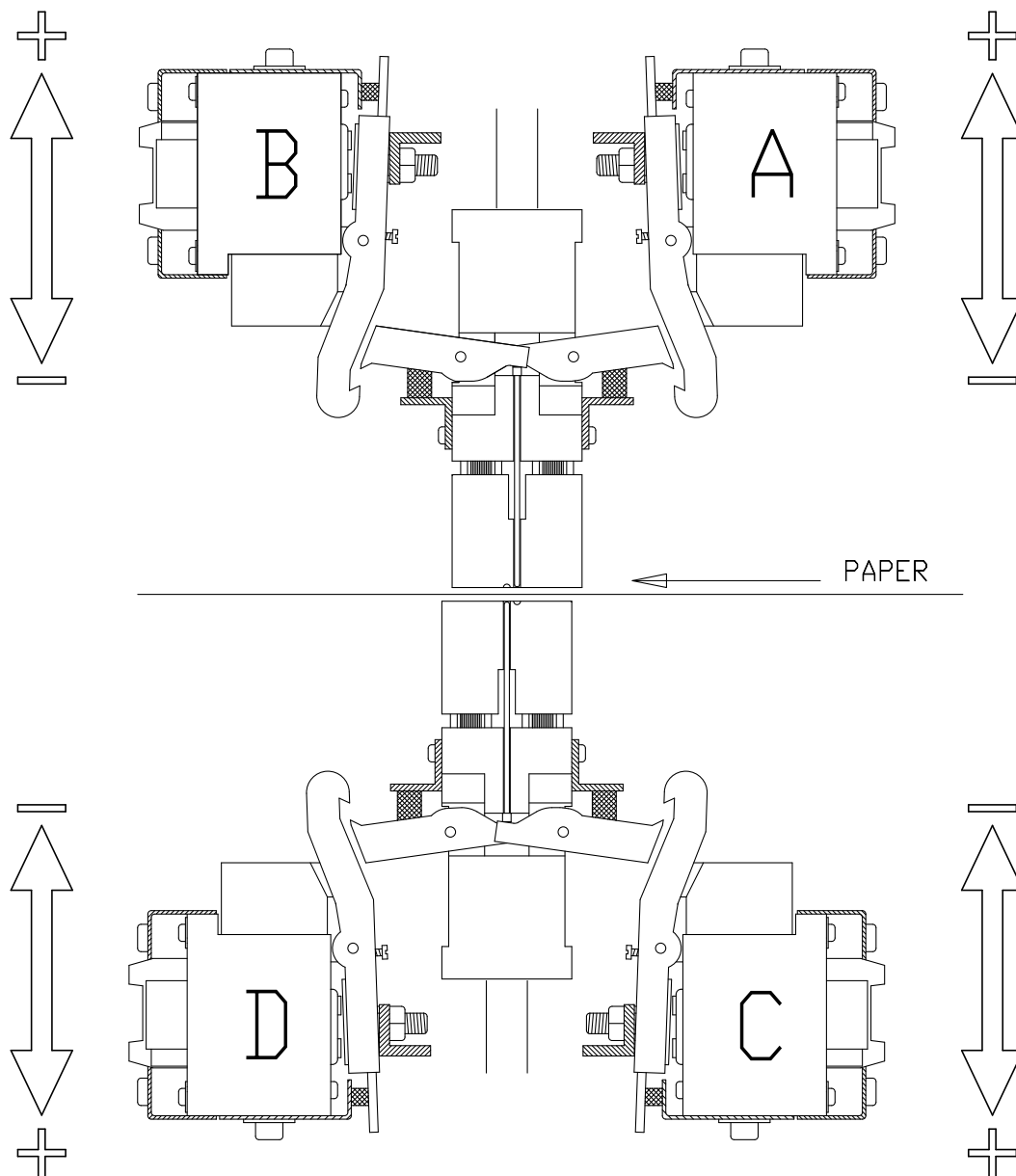

4.9 Beam and Paper shoes - Overview

Please see the figures below:

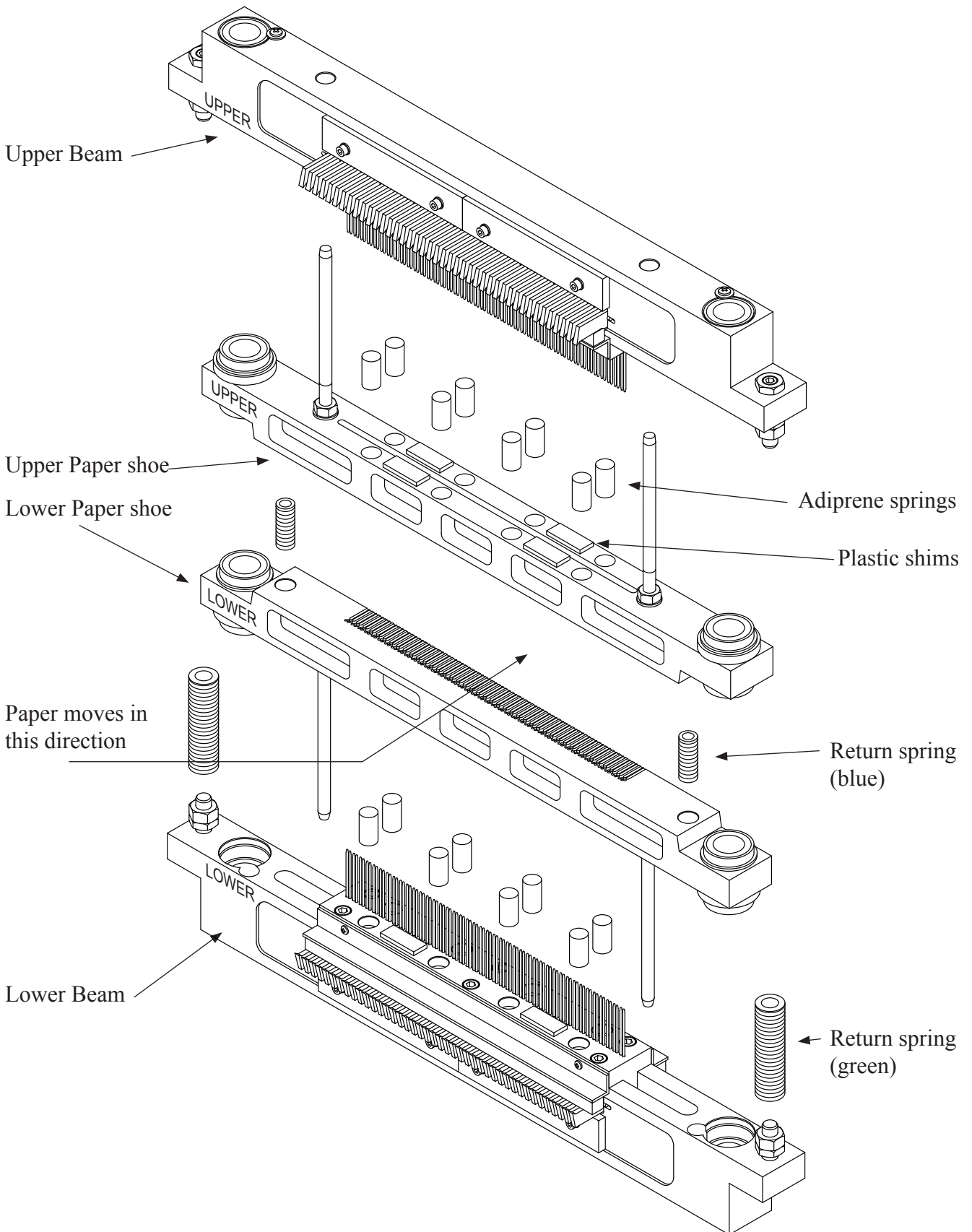

4.10 Beam and Papershoes - Removal and refitting

To remove the beam and papershoes, some other parts must be removed first. And it should be done in this order:

1. Remove the belt
2. Remove the inside paper guide
3. Remove the top frame and paper feed assembly in one piece
4. Remove the paper feed tractor
5. Remove magnet rack A and B

1. Remove the belt.

This is done by loosening the bolts for the belt tensioner. When this is done, the belt can be lifted off the upper cogwheel. Please see figure to the right.

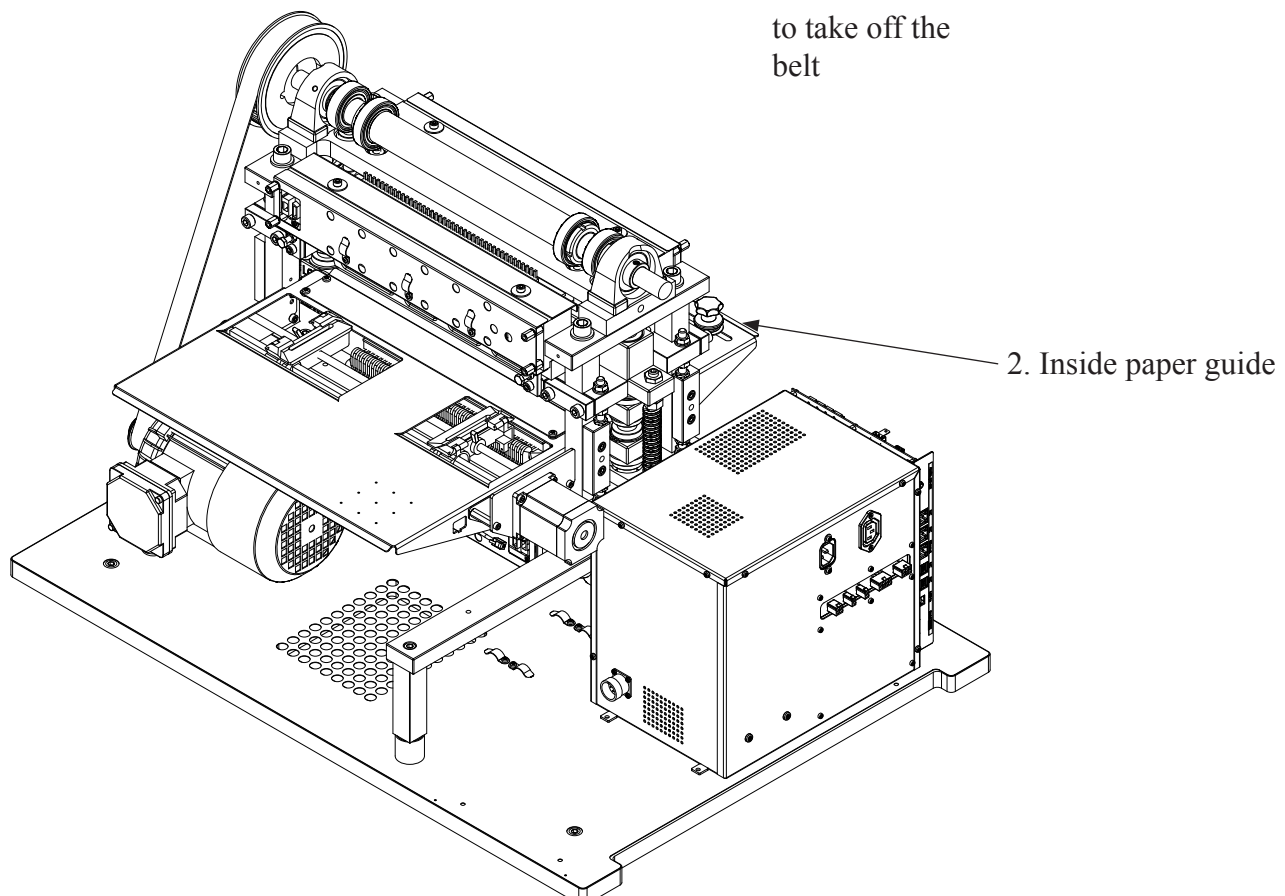
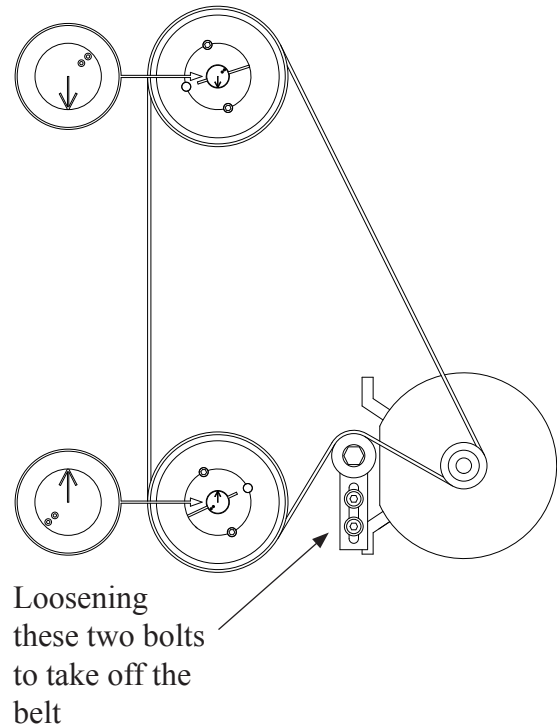

Beam and paper shoes - Removal and refitting (continued)

3. Remove the top frame.

Unscrew the bolts as indicated on the figure below, and then lift the frame carefully upwards and remove. Place aside.

When assembling, the marking "Upper" and "Lower" on the papershoes and beams, must be turned to this side.

4. Remove the paper feed tractor. Please see chapter 4.17 "Paper feed assembly - Removing" for a description on how to remove the tractor.

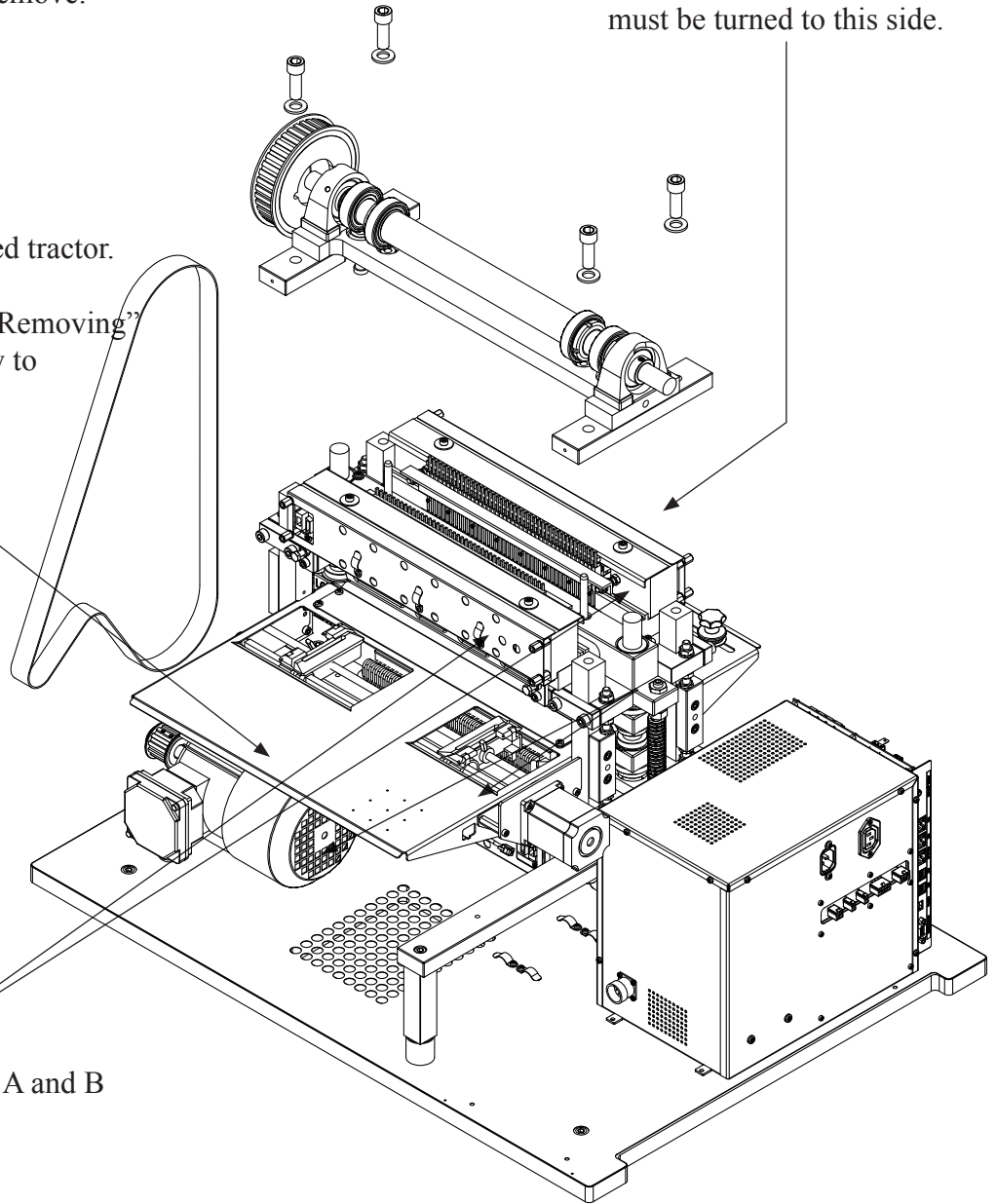

5. Remove magnet rack A and B

Now the paper shoes and beams can be lifted carefully upwards. Assembly is done in the reverse order. Please note that the marking "Upper" and "Lower" on the paper shoes and beams should be turned to the side where the paper enters the printer.

4.11 Beam - Replacement of short pivot arm

Please see the figures below:

1. Remove the two screws as indicated in the figure. Pull out the short pivot arms, there are 21 pcs. on each shaft.

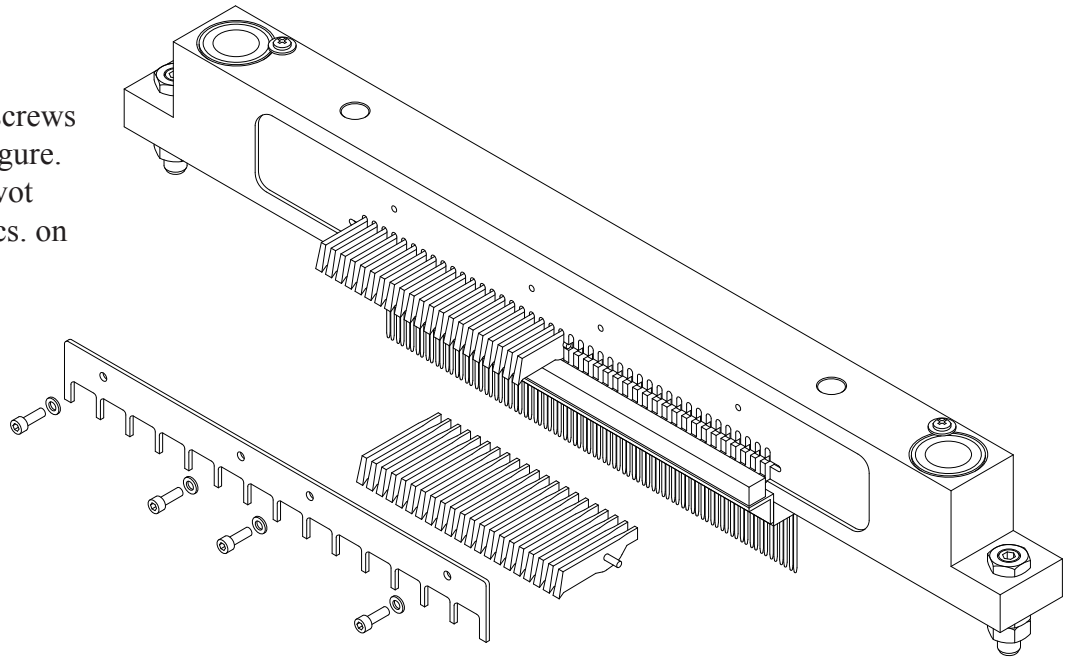

2. Pull out the shaft, and replace the short pivot arm(s).

Assembly is done in reverse order.

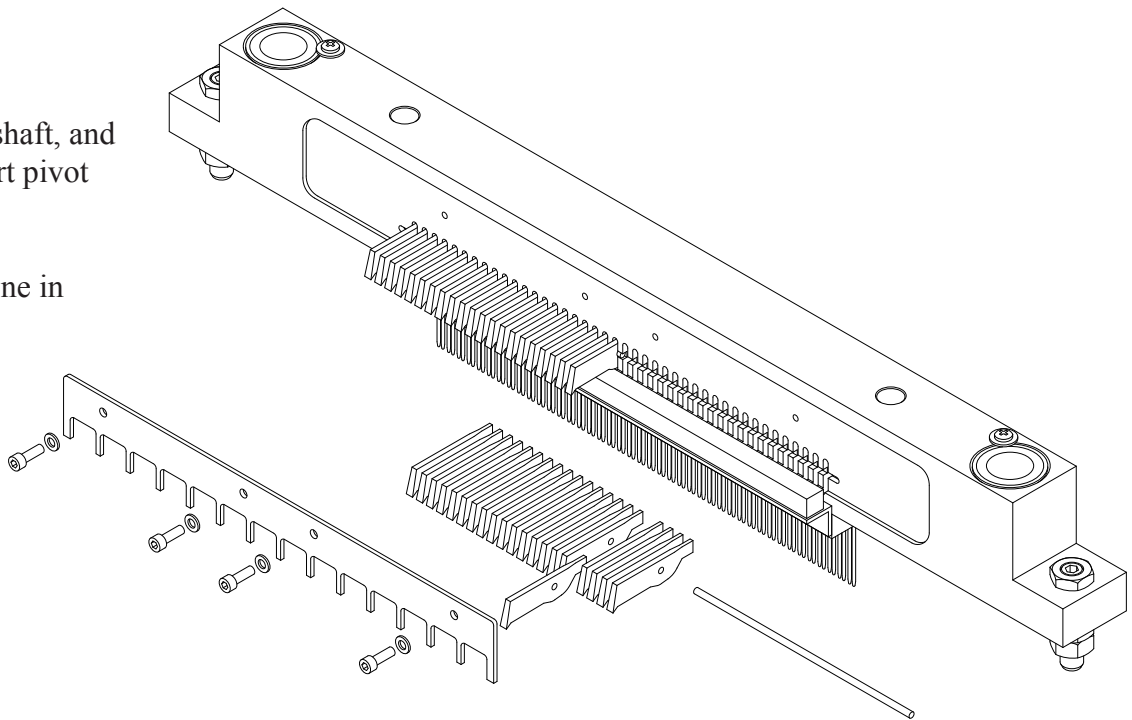

Note! When putting the short pivot arms back into the beam, be sure that the printing pins are hanging vertically like in the figure. This is to make room for the short pivot arm.

4.12 Beam - Replacement of printing pin

Please see the figures below:

Remove the six screws as indicated on the figure.

Note! Before the parts are separated, make sure that the beam is held with the printing pins hanging down.

Place the pin guide with the pins on a table. Do not turn it upside down or all the pins will fall out!!

Now the defect printing pin can be replaced.

Assembly is done in reverse order.

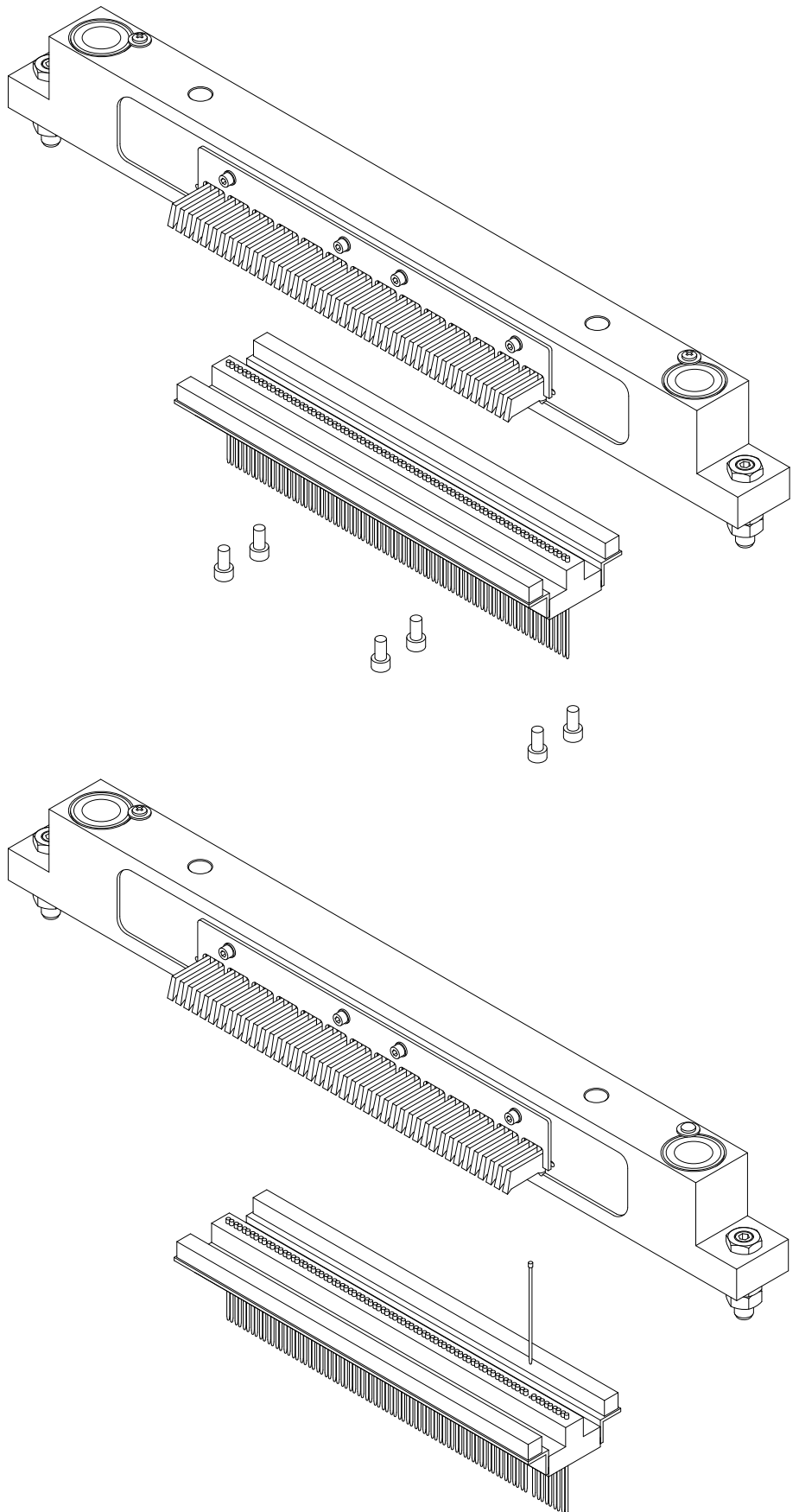

4.13 Return spring adjustment

Before performing this adjustment, make sure that the shafts are turned to the correct position. See the marks at the end of the shafts, the arrows must point directly towards each other, like in the figure below.

Then the springs can be adjusted to the correct length, i.e. 68 mm.



Note! It is critically that the length of these two return springs is 68 mm!

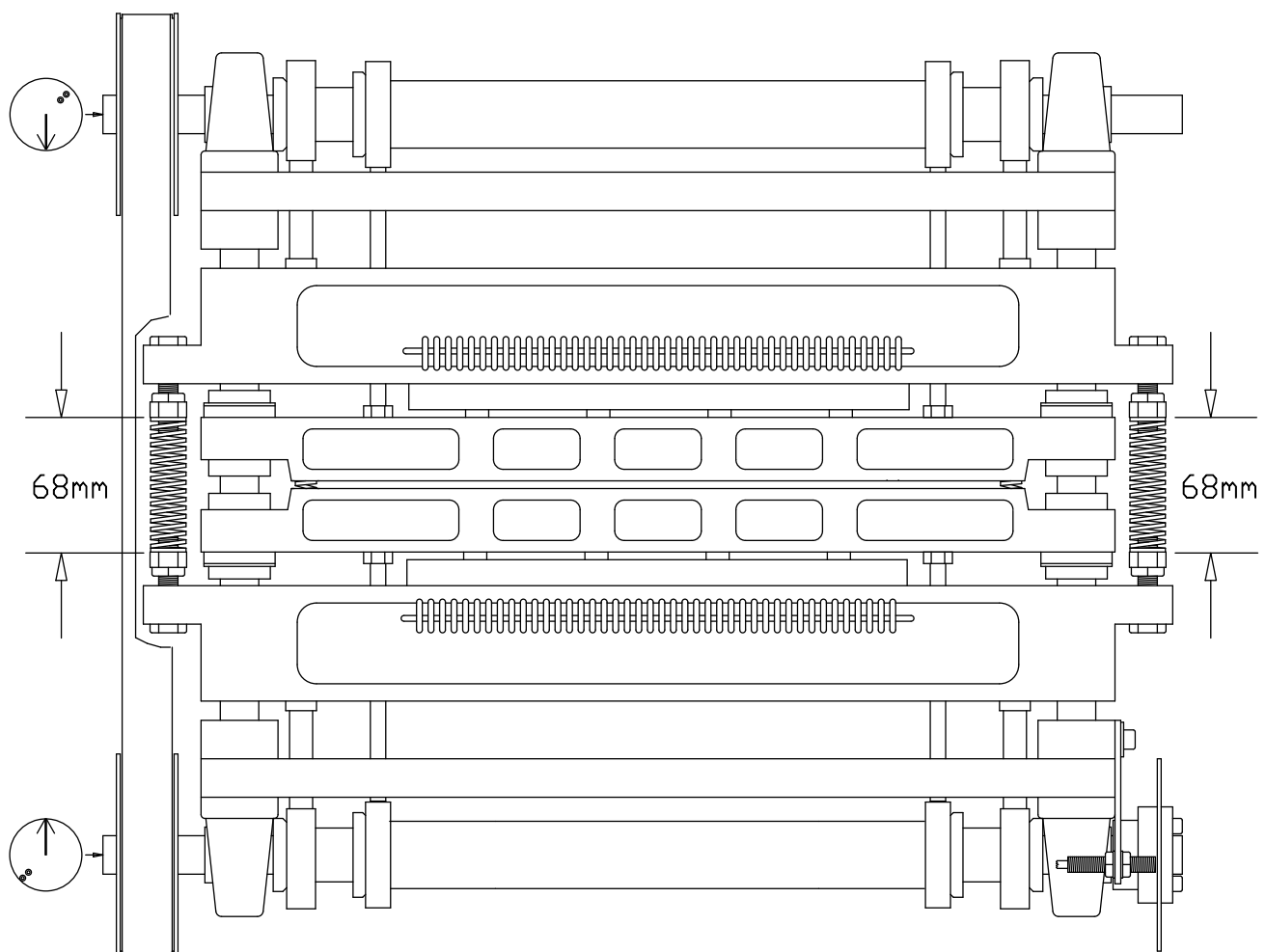

4.14 Eccentrics adjustment, belt tension

After removing the belt, it is necessary to align the eccentrics.

Put the belt back on, tighten it with the belt tightening wheel (2), and check that the arrows at the end of the shafts (1) are pointing towards each other. See figure below.

If the marks are not aligned like in the figure, it might be necessary to move the belt a notch or two on one of the wheels. This is done by loosening the belt tightening wheel (2) again, and then lift the belt up from the big wheel and move it a notch on the wheel. Then tighten the belt.

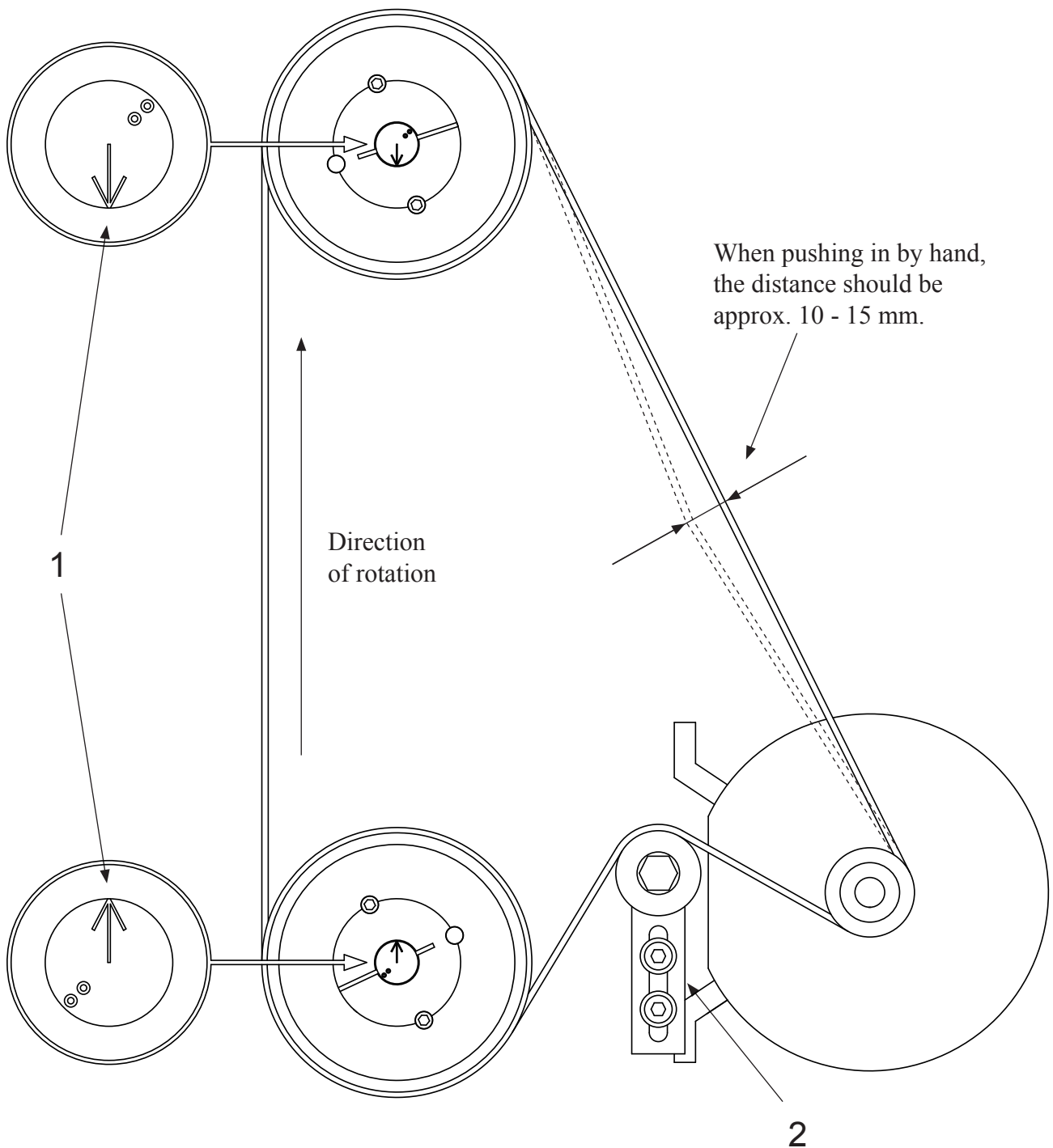

4.15 Paper shoes - Adjustment

Place a sheet of paper between the paper shoes (P).

Turn the belt so the two points (6) at the end of the shafts (2) are pointing towards each other as shown in the figure below.

Lock the shafts in this position with a wrench (vice-grip), e.g. at the end of the shaft (2).

Loosen the locking nuts (1), adjust the push rods (3) by turning them. Adjust the push rods against the inner eccentric bearing (4) until the paper shoes (P) have a light pressure on the paper.

Check that the gap (5) between the press plates and the beam above, is equal on both upper and lower units.

Secure the push rods (3) with the locking nuts (1).



Note! The function of the bearings (4), is to reduce the noise the printer makes while running. It is a common misunderstanding that you can increase the pressure on the papershoes by adjusting these push rods. This does not have any influence on the dot quality!

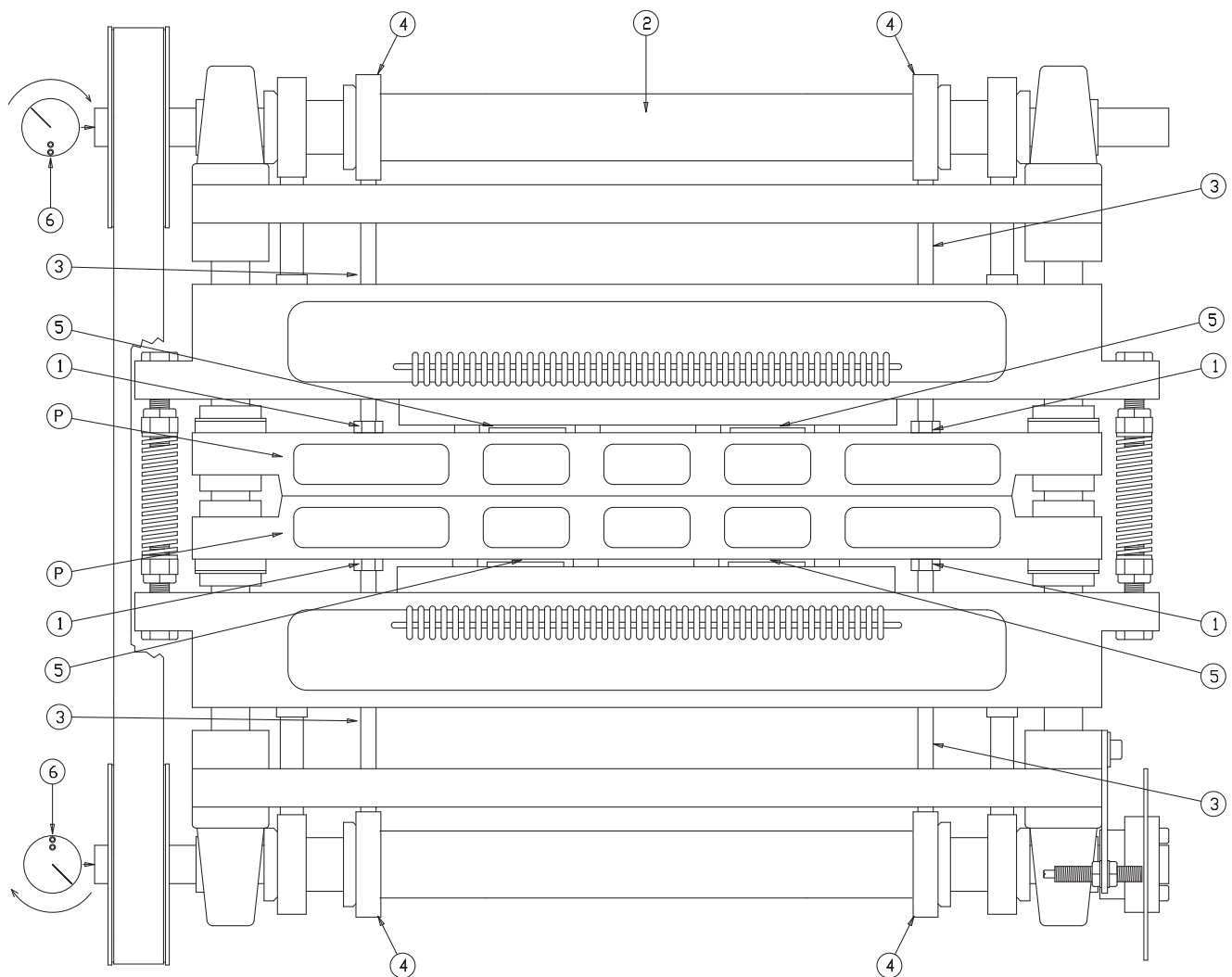

4.16 Main sensor wheel - Adjustment

The main sensor wheel is placed on the lower shaft, on the opposite end from the belt. The shafts must be in the position indicated to the left in the figure below. The timing wheel should now be be placed exactly like position (A) in the figure below.

If the timing wheel is not in it's correct position, it must be adjusted. Keep the shafts in this position while loosen the two screws (B) holding the timing wheel. Turn the timing wheel until the inductive sensor is placed in the middle of the opening in wheel. Then fasten the two screws again.

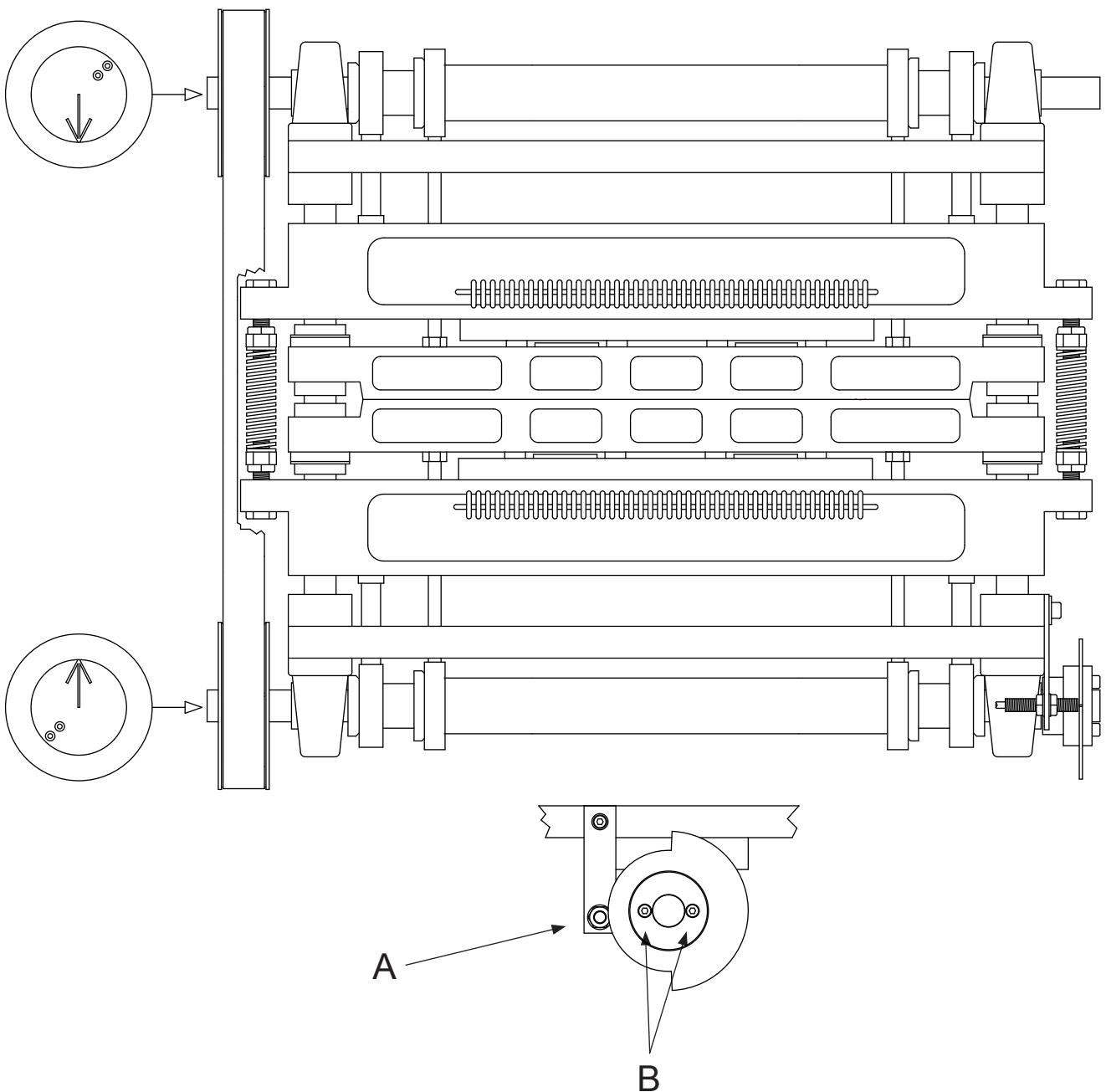

4.17 Paper feed assembly - Removing

The paper feed assembly can be removed by loosening the screws (A). There is no need to remove the screws completely, just loose them, and then lift the assembly up and pull out.

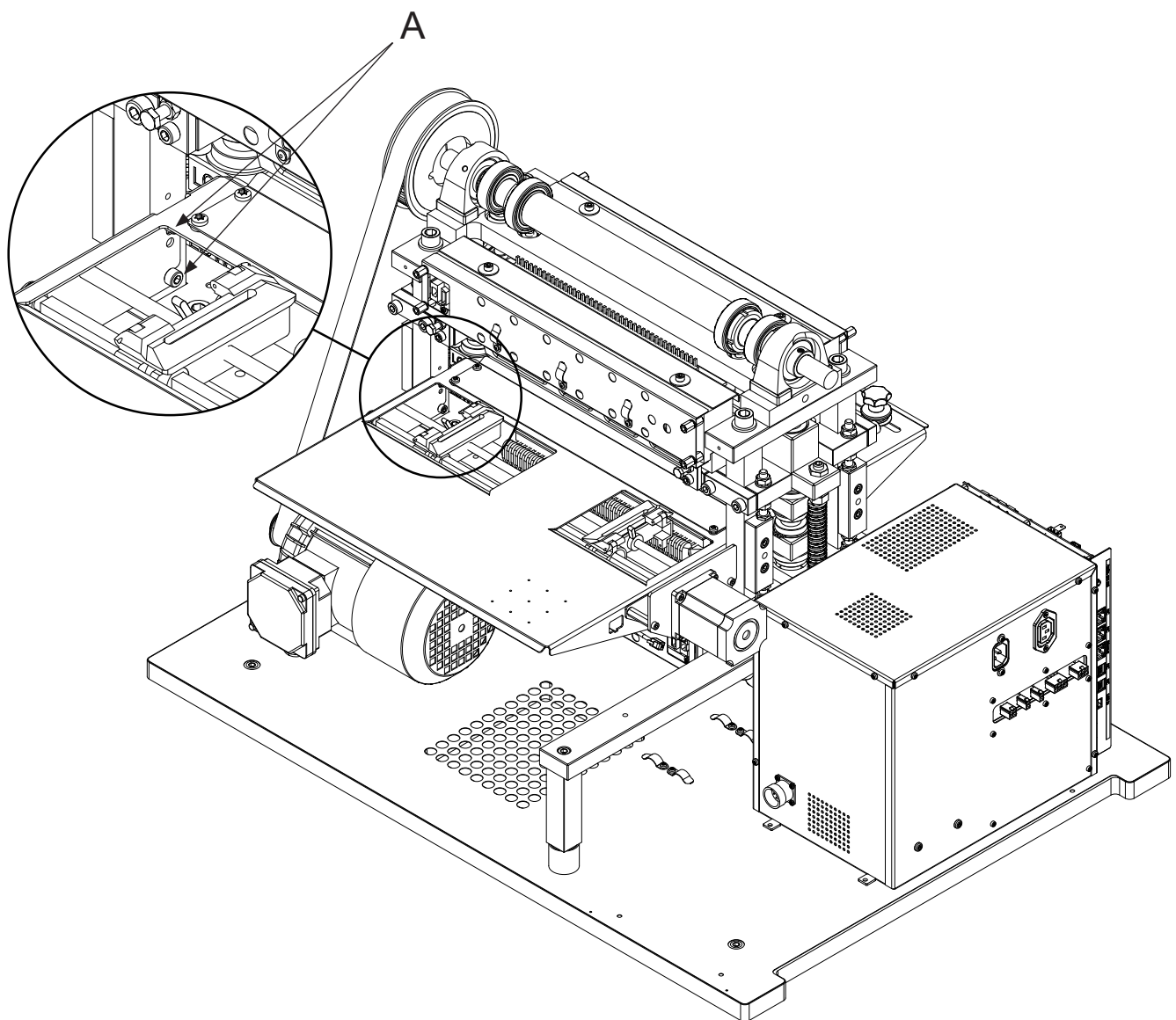

4.18 Paper feed assembly - Adjustment

If for some reason the paper feed mechanism has been disassembled it could be that the paper will not stop correctly by the marks on the paper guide.

Therefore, it is necessary to adjust the relation between the paper parking position and where the stepping motor is parking.

Loosen the paper feed shaft by unscrewing the two left-hand screws (B) on the sensor wheel.

Note ! Do not loosen the screws for the stepping motor shaft.

Put a sheet of paper into the tractors on the paper feed.

Now the tractor feed shaft can be turned forward or backward until the paper is in the desired position.

Tighten the screws (B) again.

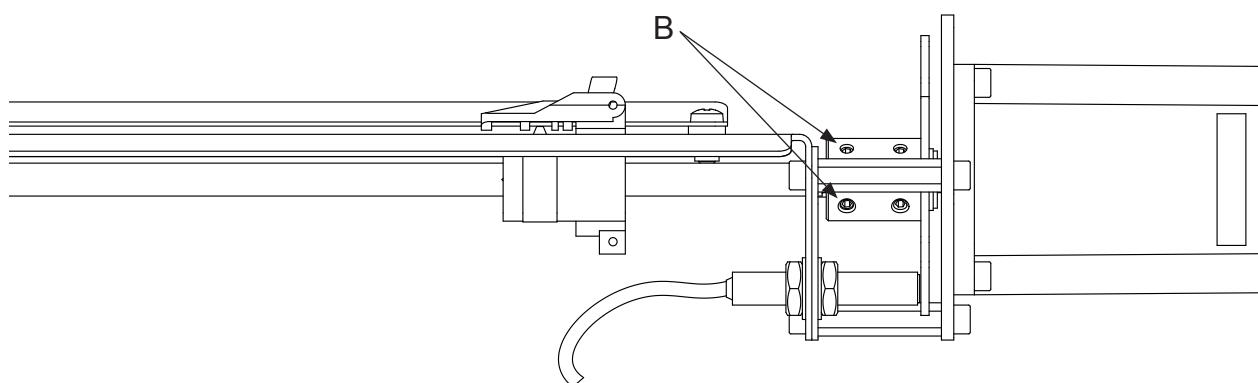

4.19 Inductive sensors - Adjustment

This printer uses inductive sensors in three places. One for the main timing wheel on the lower shaft, and two are controlling the movement in the paper feed mechanism.

It is possible to check if the inductive sensors are functioning, by looking at the rear end where the cable enters the sensor. Inside the sensor is a little LED lamp that will be lit if a magnetic object is in front of the sensor. The light comes out through some transparent plastic around the cable. So by having the power turned on, and at the same time turning the shafts, the light should go on and off.

When replacing/adjusting the sensors, the gap between the timing wheel and the sensors can be maximum 0.6 mm. See figure below.

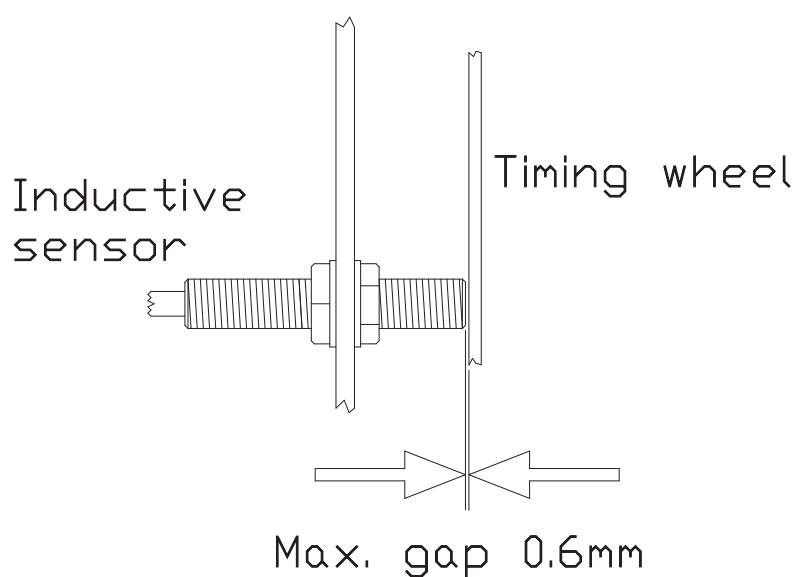

4.20 Paper sensor - Replacing

This printer has a sensor to detect if paper is present in the printer.

This sensor is situated on the paper guide where the paper enters the printer.

The sensor is an infrared, reflective type, and it functions like this: A little infrared lamp is sending light downward. If there is paper present, the light will be reflected back, and detected by a photo transistor. If the sensor is defective, it must be replaced. It can be done like this:

Take the paper guide out of the printer. Unscrew first the screws (A), then (B) and then (C). Now the sensor is loose. The assembly is done in reverse order.

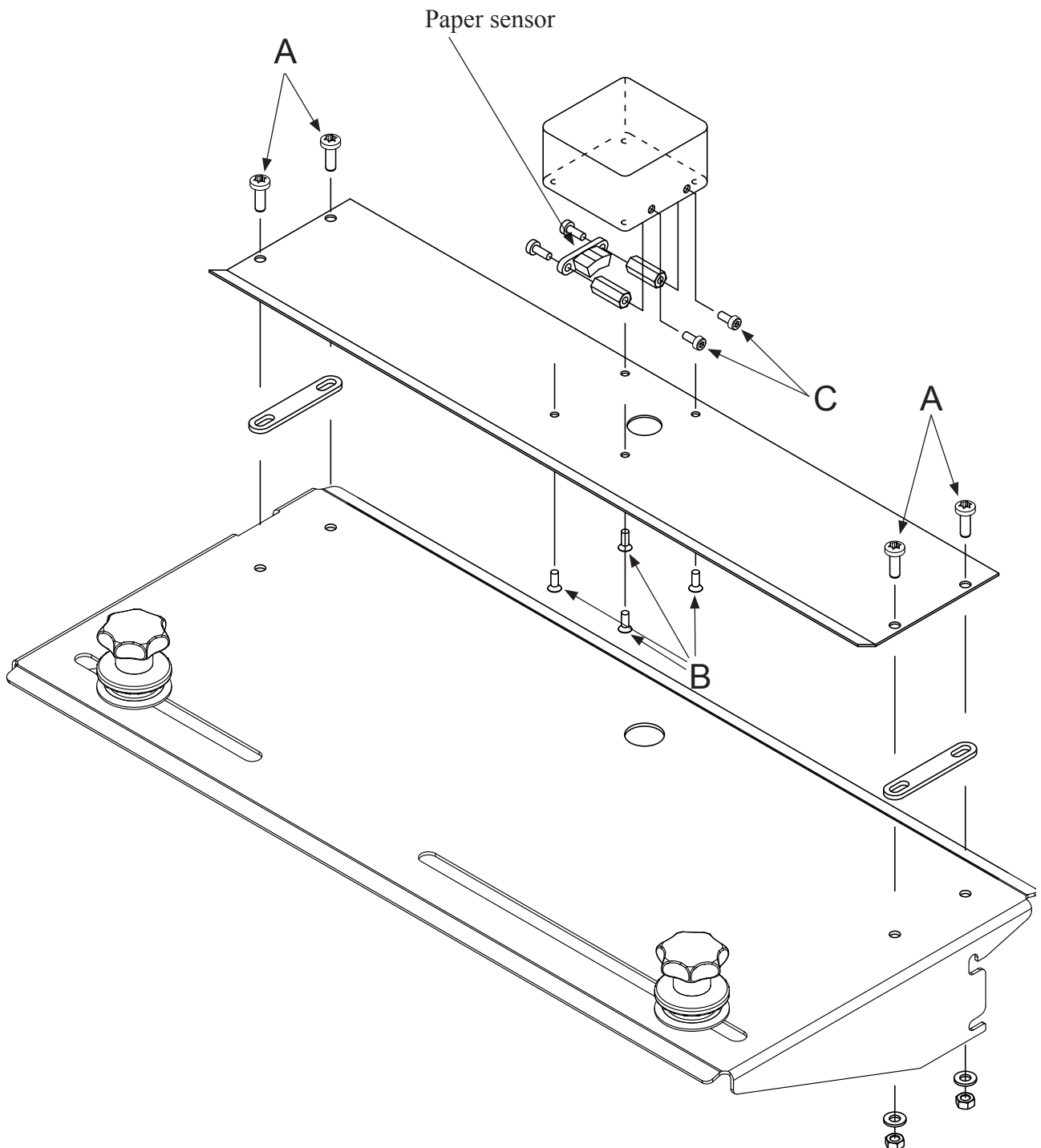

4.21 Maintenance

Weekly (without taking the cover off).

Does the printer print correct Braille?

How is the Braille dot quality?

Check for any damages on the outside of the cover.

Are the operator panel and display functioning?

Do the fans work? Are the fans clean?

If there is a lot of dust from the paper on the paper guides, use a vacuum cleaner.

Every 500 hours or six months.

All of the weekly maintenance.

Is the printer mechanism, electric unit, base plate and so on clean? Use a vacuum cleaner to remove the dust.

Check the main belt for wear, tear, cracks and check the tension.

Check the tractor belts for wear, tear, and cracks. Be sure to check the small “spikes” of the tractor belts very carefully.

Clean the magnet racks.

Check the sponges for the long pivot arms on the four magnet racks, the sponge should be able to keep the long pivot arms pressed against the support list.

When putting the magnet racks back in, check all the magnet rack adjustments.

Check if the printing pins move freely, and if not, clean the printing pin guide.

Every 1000 hours or twelve months.

All of the 500 hours or six months maintenance.

Check the four sponges for the short pivot arms, the sponge should be able to keep the short pivot arm pressed all to the end of its travelling distance.

Check the tear and wear on the push rod (12 x 56). This can be measured with a calliper, and the length must be between 55.90 to 56.00 mm.

Check if the paper shoes are worn. The printer should be able to give good Braille dot quality, but if not, worn papershoes could be the reason.

Check the length on the printing pin. This can be measured with a calliper, and the length must be between 64.40 and 64.50 mm.

Lubricate all the stroke ball bearings, using a universal grease with molybdensulfid.

Lubrication should be done as described in figure on the next page.

Lubrication

This should be done every 1000 running hours, or approximately once a year.
 Lubricate all items marked “1” on the figure below. (These are the only locations in the printer grease may be applied!).

Use a universal grease with molybdensulfid.

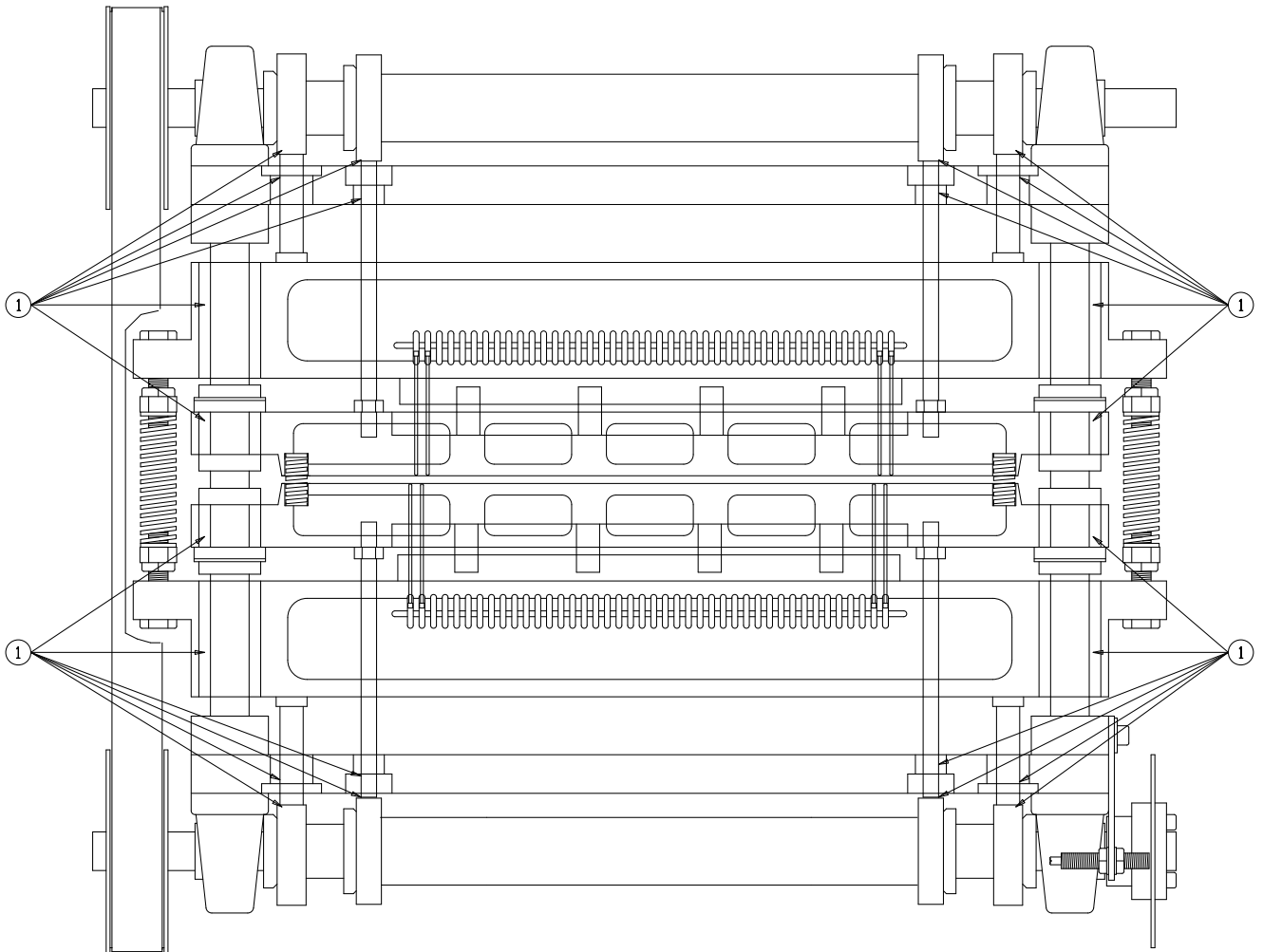

5. PARTS - EXPLODED VIEWS

5.1 Magnet rack

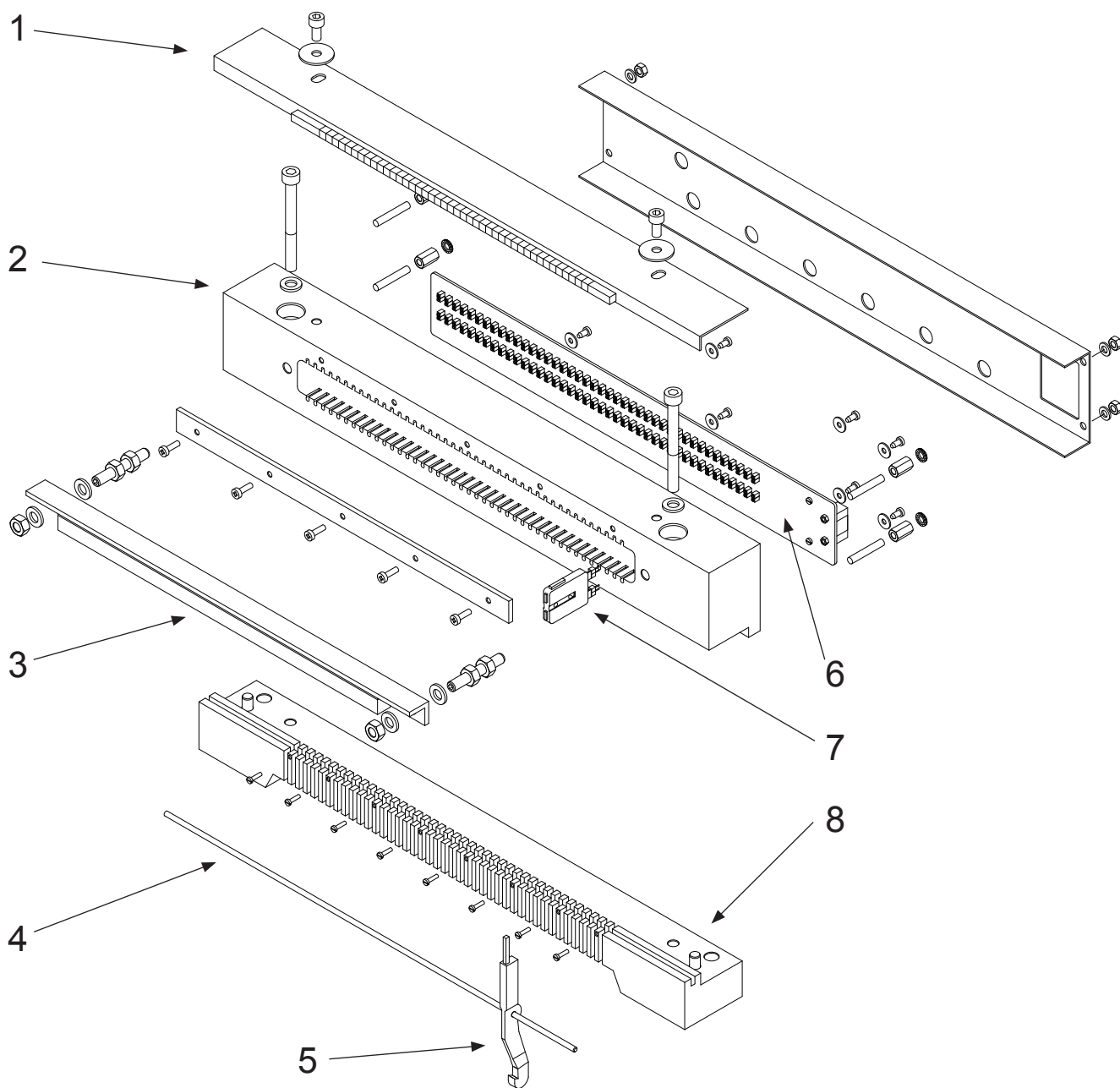

Parts magnet rack

Pos	Name	Quantity per. rack
1	Sponge list, magnet rack	1
2	Magnet rack	1
3	Support list, magnet rack	1
4	Shaft, long pivot arm.....	1
5	Pivot arm, long.....	42
6	Electronic board, magnet rack	1
7	Magnet	42
8	Guide list, magnet rack	1

5.2 Beam

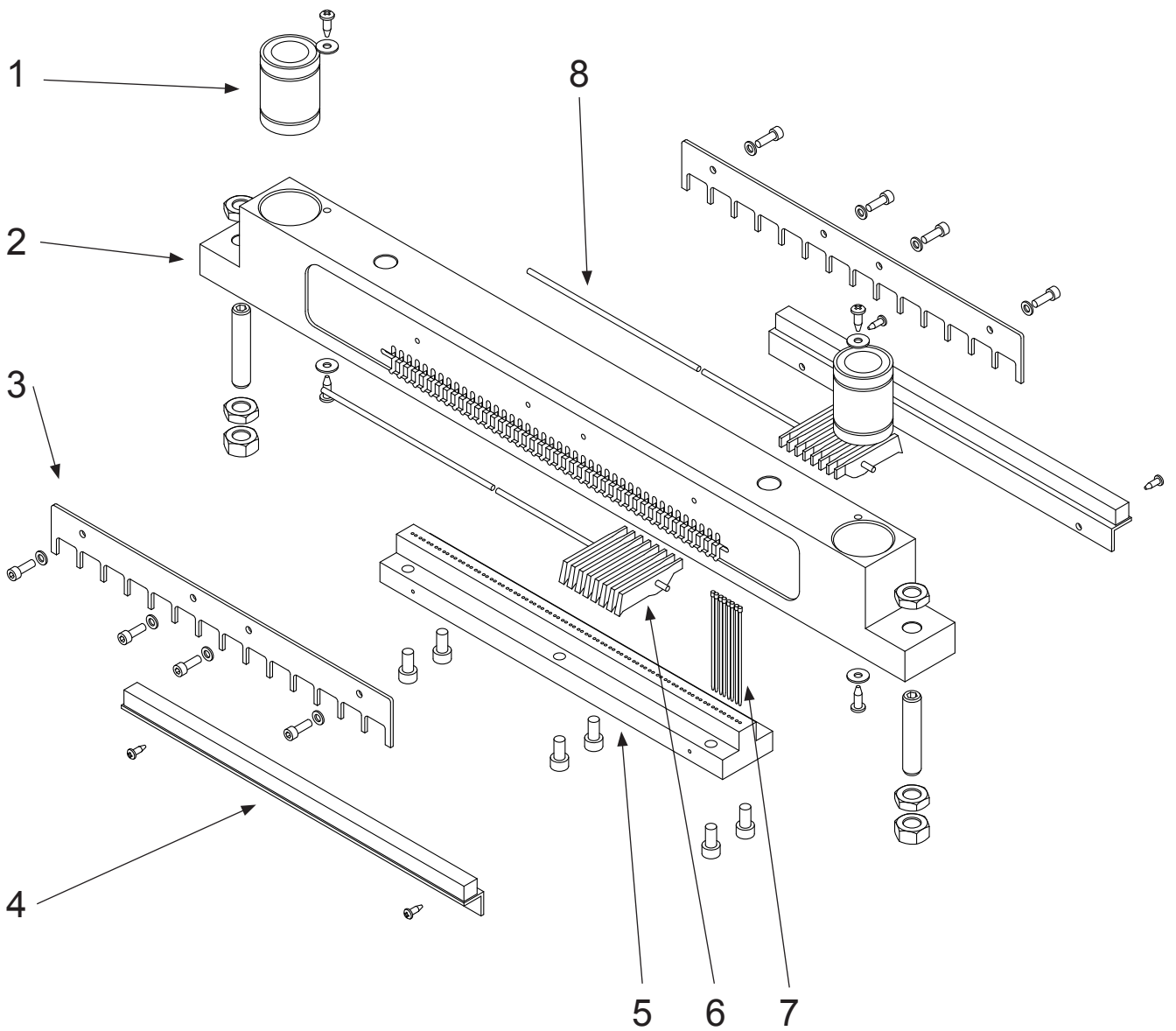

Parts beam (upper and lower)

Pos	Name	Quantity per. beam
1	Stroke ball bearing Ø20	2
2	Beam, (upper and lower)	1
3	Fastener for shaft short pivot arm	2
4	Sponge list for short pivot arm	2
5	Pin guide	1
6	Short pivot arm	84
7	Printing pin, length = 64.5 mm	84
8	Shaft, short pivot arm	4

5.3 Paper shoe

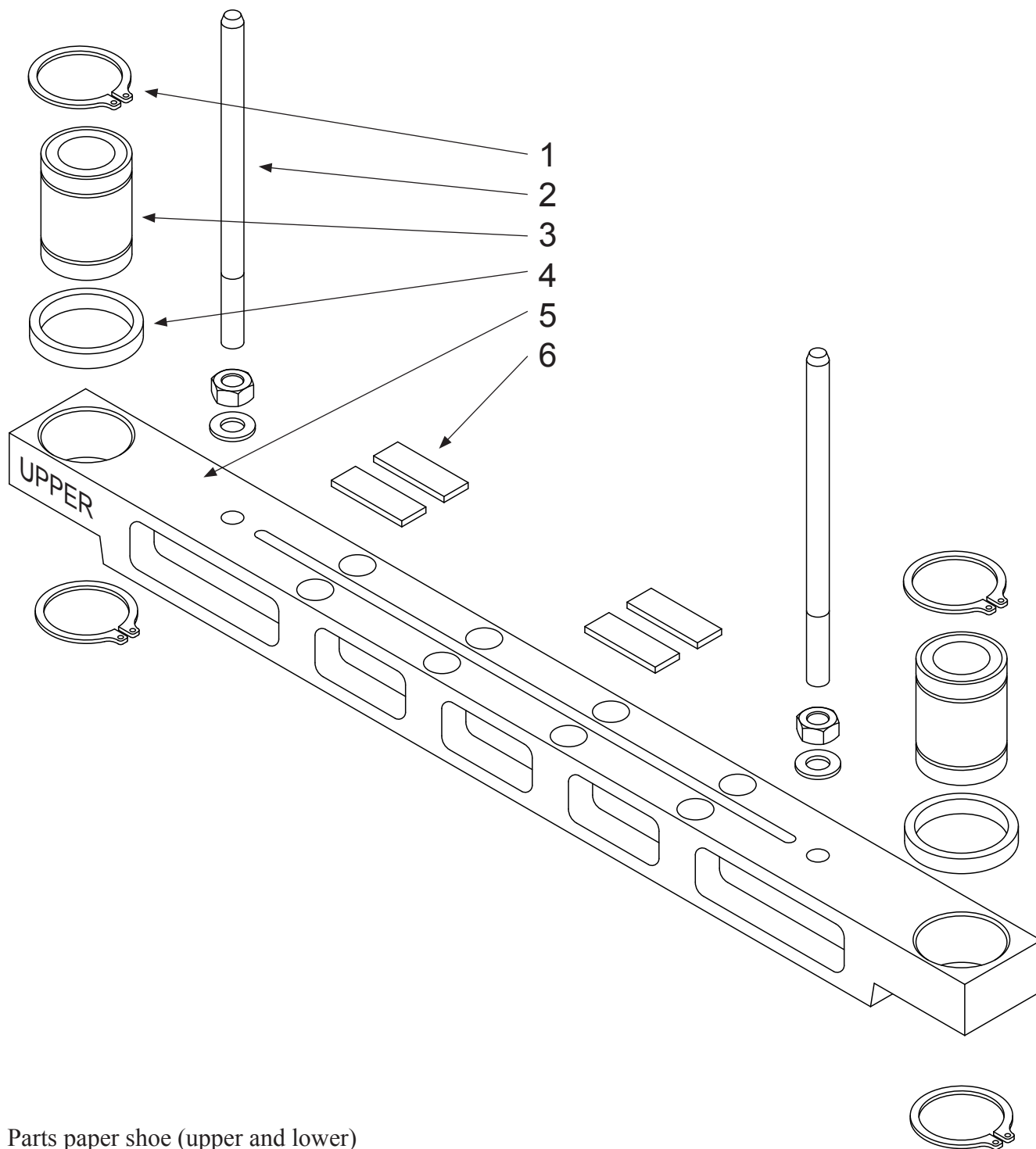

Parts paper shoe (upper and lower)

Pos	Name	Quantity per. shoe
1	Retaining ring	4
2	Adjustment screw (push rod)	2
3	Stroke ball bearing Ø20	2
4	Spacer	2
5	Paper shoe (upper and lower)	1
6	Plastic shims	4

5.4 Paper feed

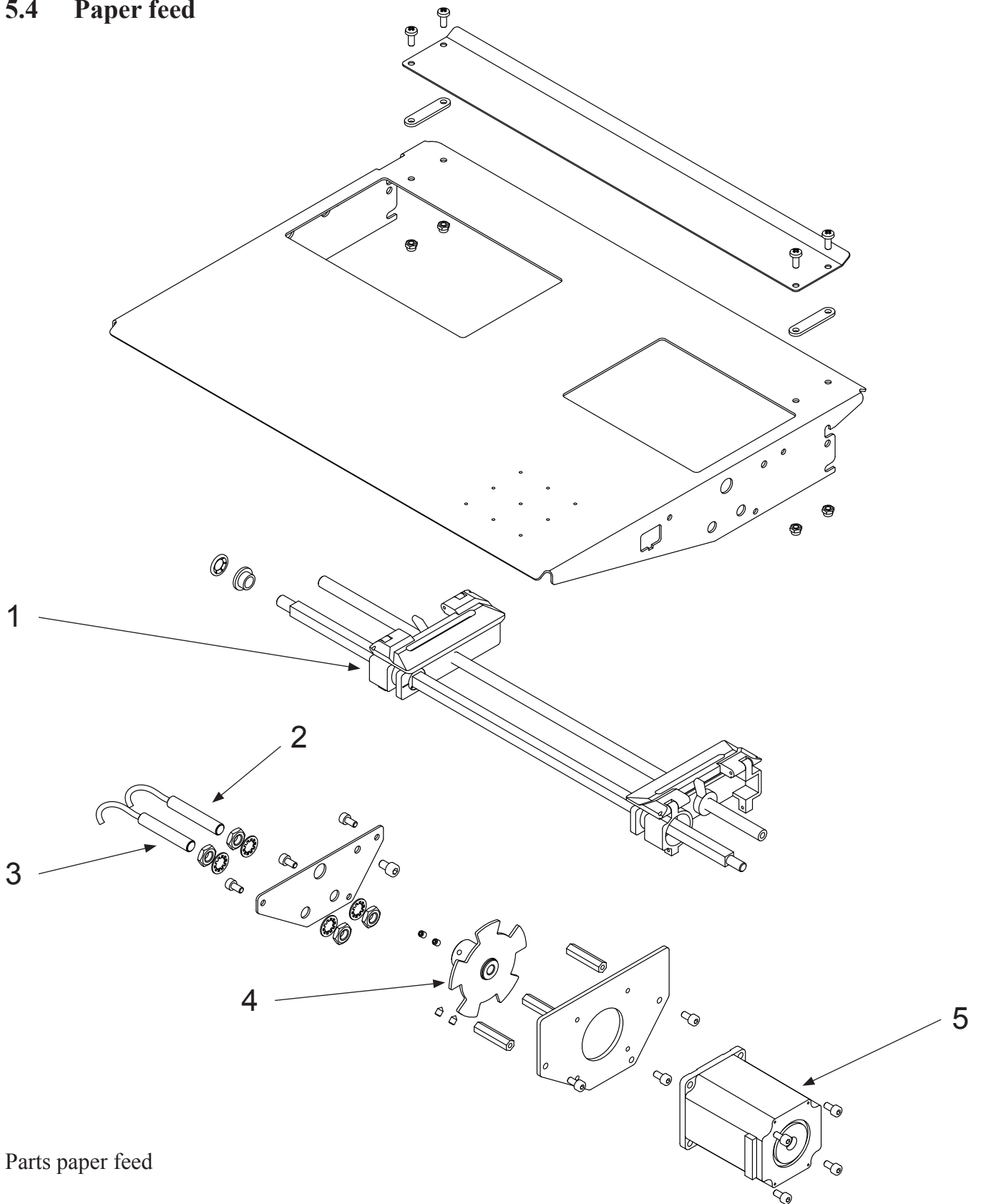

Parts paper feed

Pos	Name	Quantity
1	Paper feed tractor	2
2	Paper feed sensor no. 1	1
3	Paper feed sensor no. 2	1
4	Timing wheel	1
5	Stepping motor.....	1

5.5 Shafts, belt

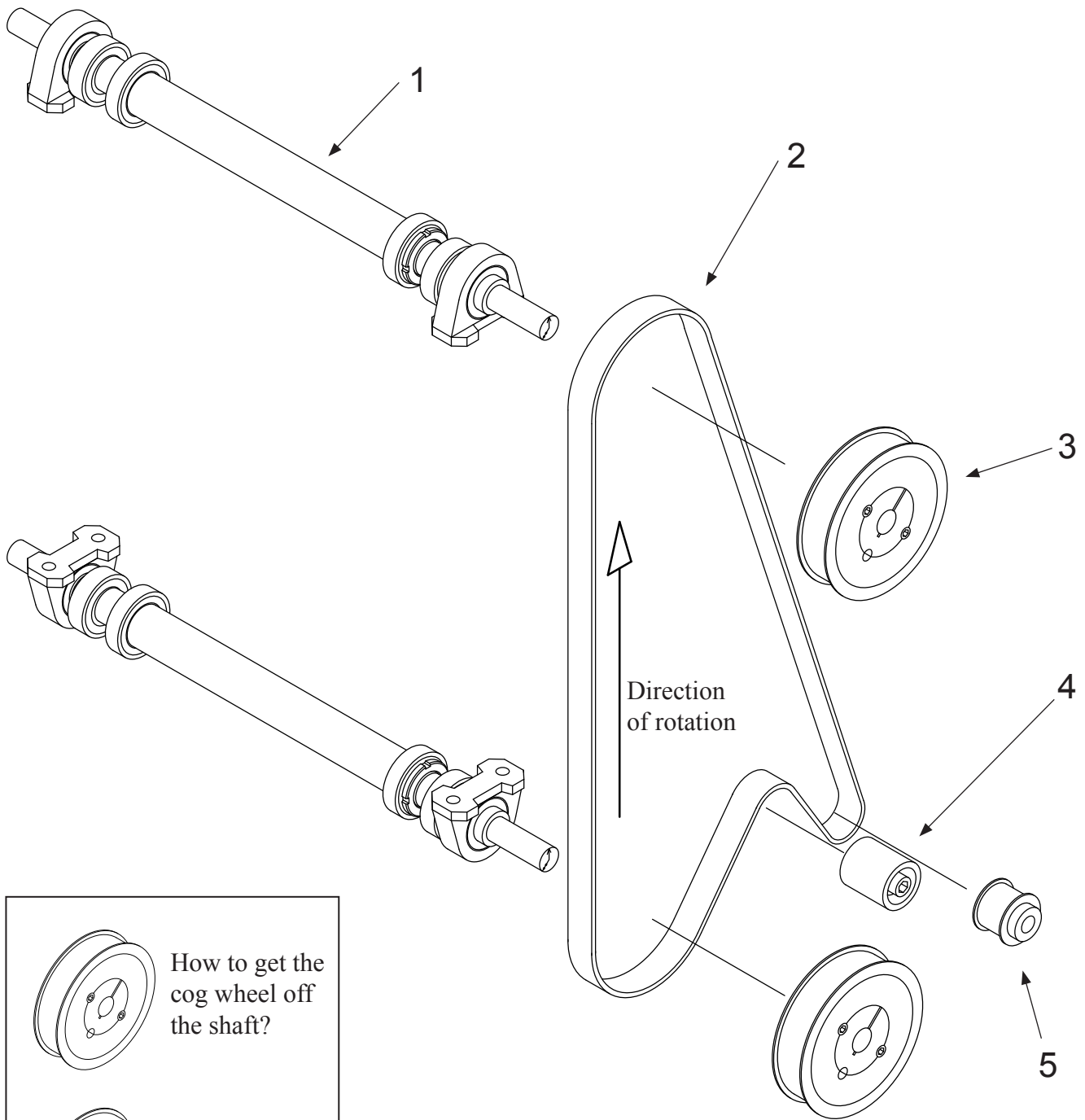

How to get the cog wheel off the shaft?

Unscrew the two screws.

Place one of the screws in the third hole, and screw it inwards until the wheel is loose.

Parts shaft, belt

Pos	Name	Quantity
1	Shaft, complete with bearings	2
2	Belt 540 L.....	1
3	Cog wheel 40 L 100	2
4	Belt tensioner	1
5	Cog wheel 12 L 100	1

Shaft, exploded view

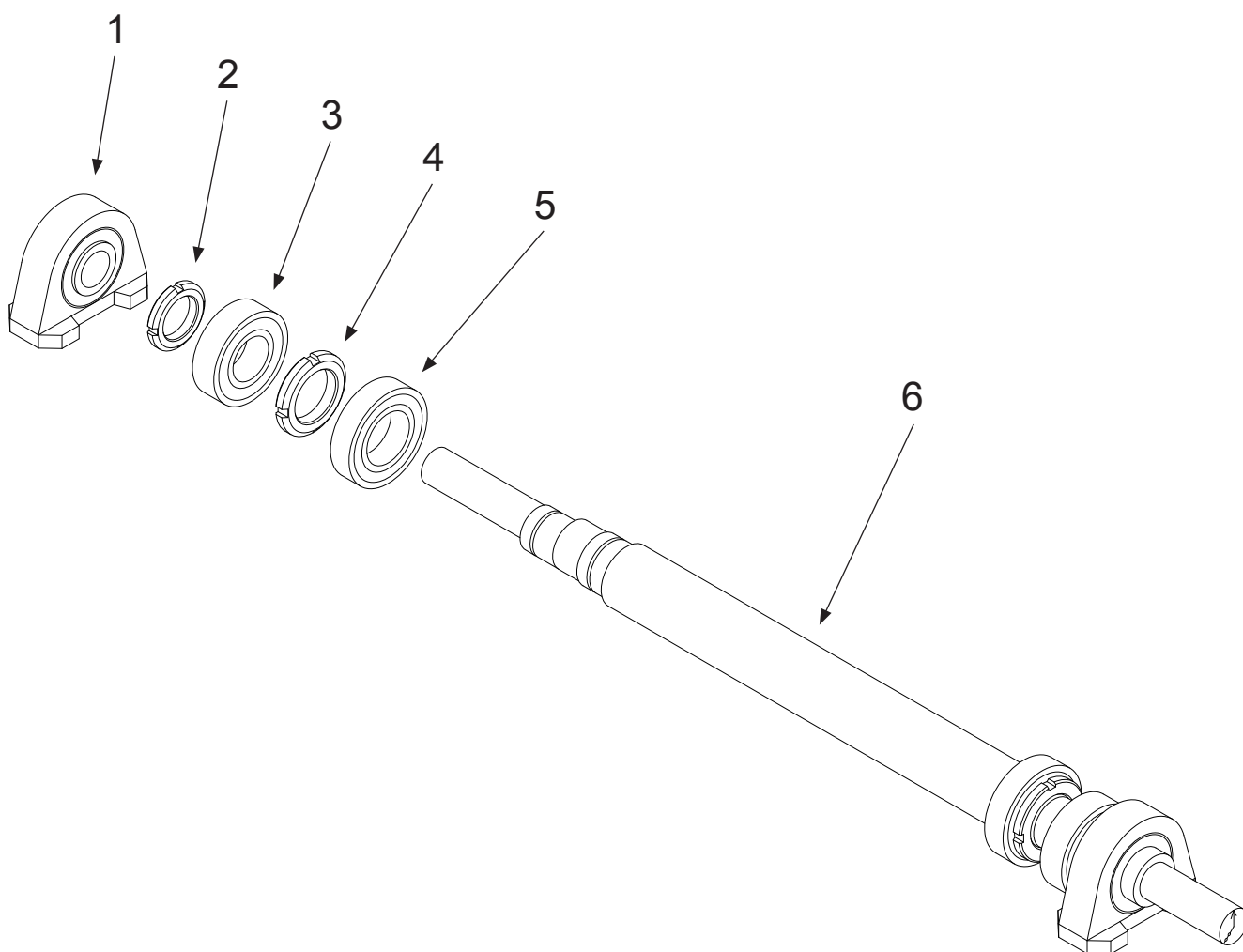

Parts shaft, exploded

Pos	Name	Quantity per. shaft
1	Main bearing with housing	2
2	Nut KM5	2
3	Bearing outer eccentric 6205 2Z.....	2
4	Nut KM6	2
5	Bearing inner eccentric 6006 2Z.....	2
6	Shaft	1

5.6 Top and bottom frame

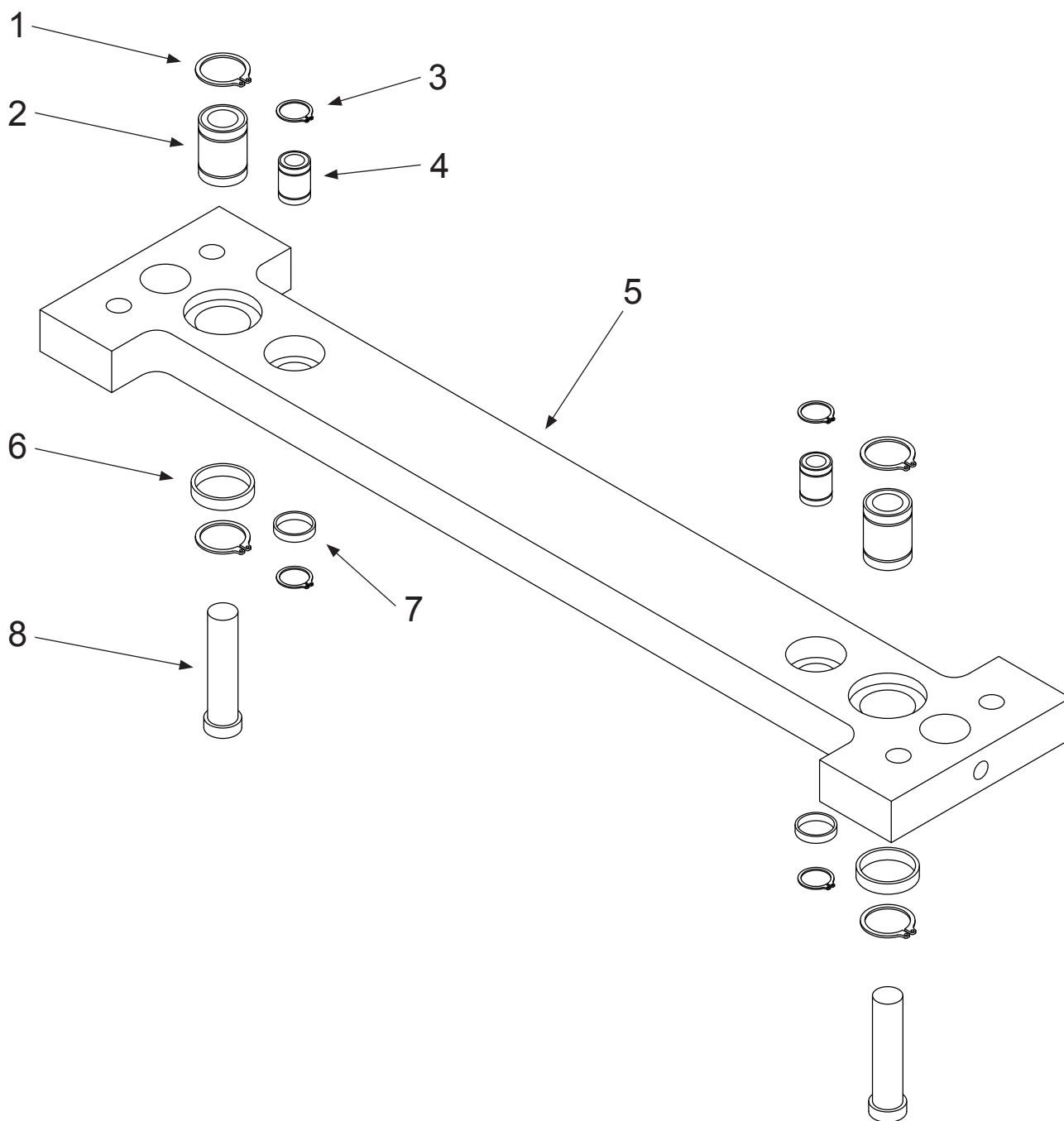

Parts top and bottom frame, exploded

Pos	Name	Quantity per. frame
1	Locking ring Ø22	4
2	Stroke ball bearing Ø12	2
3	Locking ring Ø16	4
4	Stroke ball bearing Ø8	2
5	Frame	1
6	Spacer Ø22	2
7	Spacer Ø16	2
8	Push rod ceramic Ø12X56	2

Frame, complete

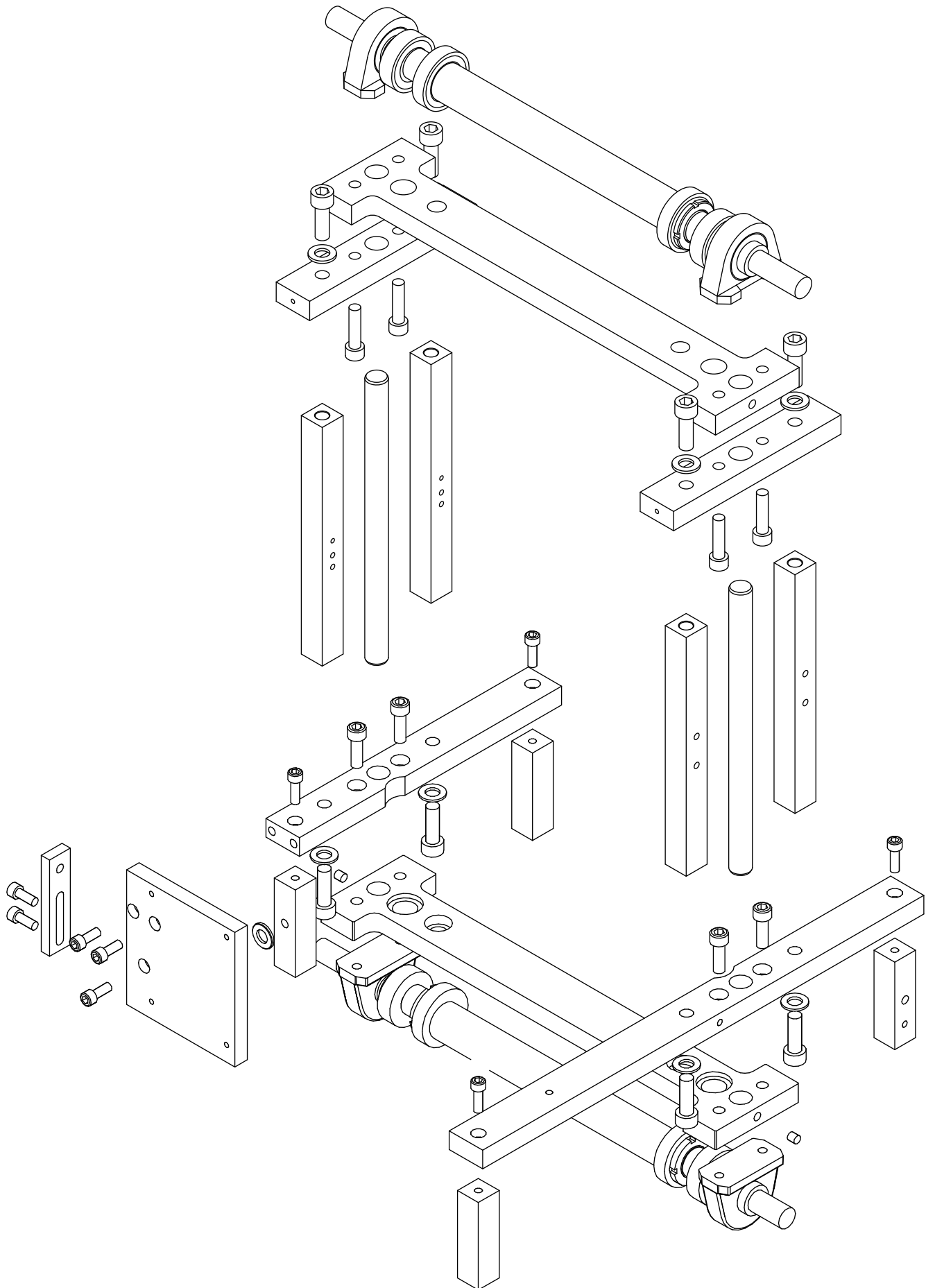

6. TECHNICAL SPECIFICATIONS

6.1 Technical specifications

Format:

Characters per line:	10-42 char.
Sheet length:	4-14 inches
Sheet width:	140-330 mm
Page layout:	Normal/Z-fold
Page 1:	Up/down
Printing type:	Single sided/interpoint
Line spacing:	Adjustable, from 0.3175 mm to 10.16 mm. Standard is 5.08 mm
Dot:	6/8
Page length:	No form feed/normal/normal-1 to -9 lines
Braille cell:	Standard medium 6 or 8 dot.
Paper weight:	120 - 180 g/m ² , recommended 150 g/m ²

Printing speed: Upto 300 characters per second or a maximum of 900 printed pages per hour (based on a 12 inch sheet).

Electrical:

Voltage:	Single phase 230V (+/- 10 %), 50/60 Hz
Current:	approximately 5 A max.
Fuse Printer:	10 A
Power:	approximately 1000 W max.

Communication with the computer:

USB
Ethernet

Environment:

Temperatures:	15-30 C (60-86 F)
Rel. Humidity:	40-60%

Measurements:

Height:	650 mm
Width:	700 mm
Length:	920 mm
Weight:	145 Kg

Patents:

Norway	no. 140335
Great Britain	no. 2040231
USA	no. 4261663
Germany	no. DE 2850780 C22

6.2 Electric unit - Overview

The electric unit is placed on the base plate of the Printer, and contains connections, fuses and power supply. Note that you must disconnect the mains when working on this unit.

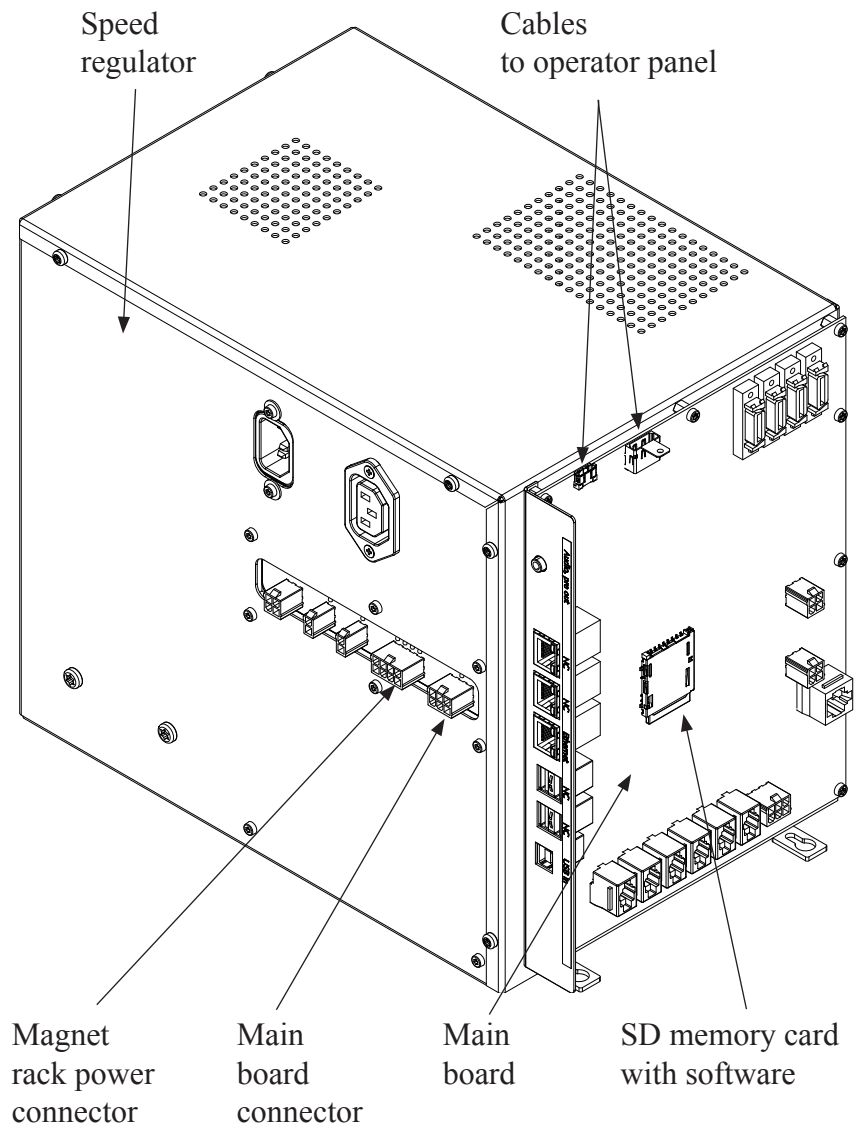

6.3 How to replace fuses

The fuses are placed on a PCB inside the Electric Unit. See figures below for how to open the box. Remember to disconnect the mains cable first!

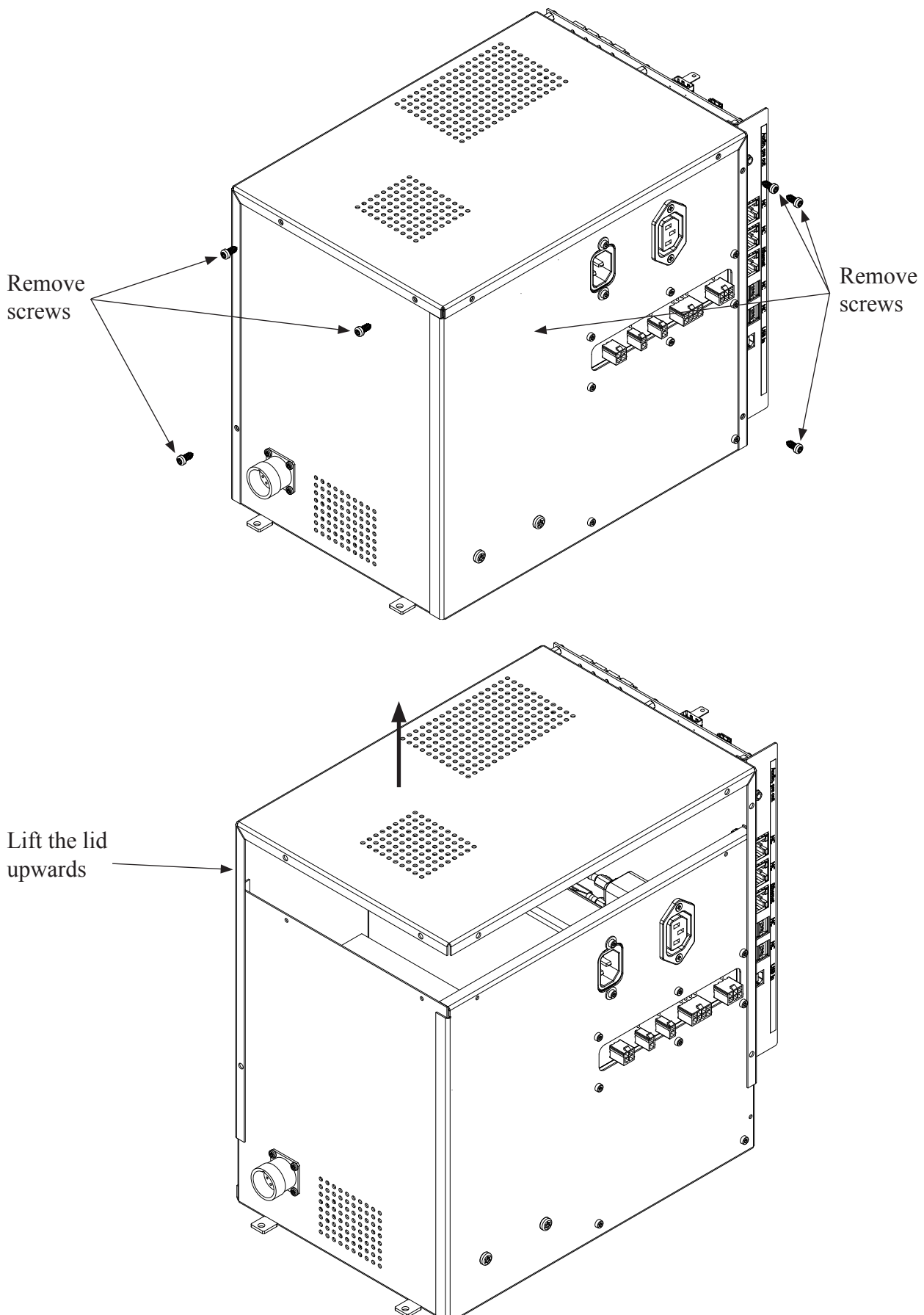

The fuses.

Note that the two mains fuses is placed under transparent lids. All the fuses are 5 x 20 mm and can be of glass or ceramic type.

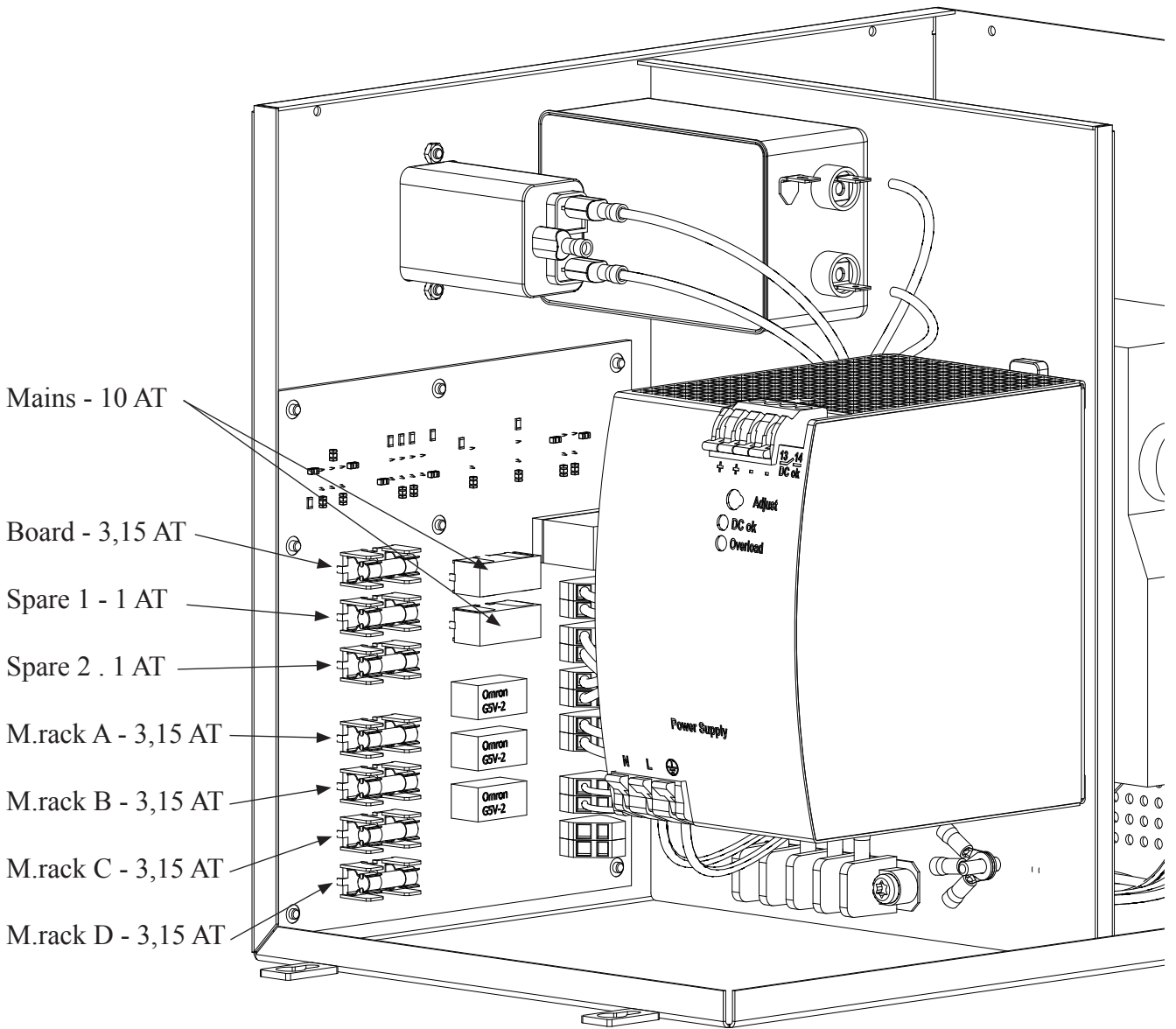

6.4 Main board - Connections

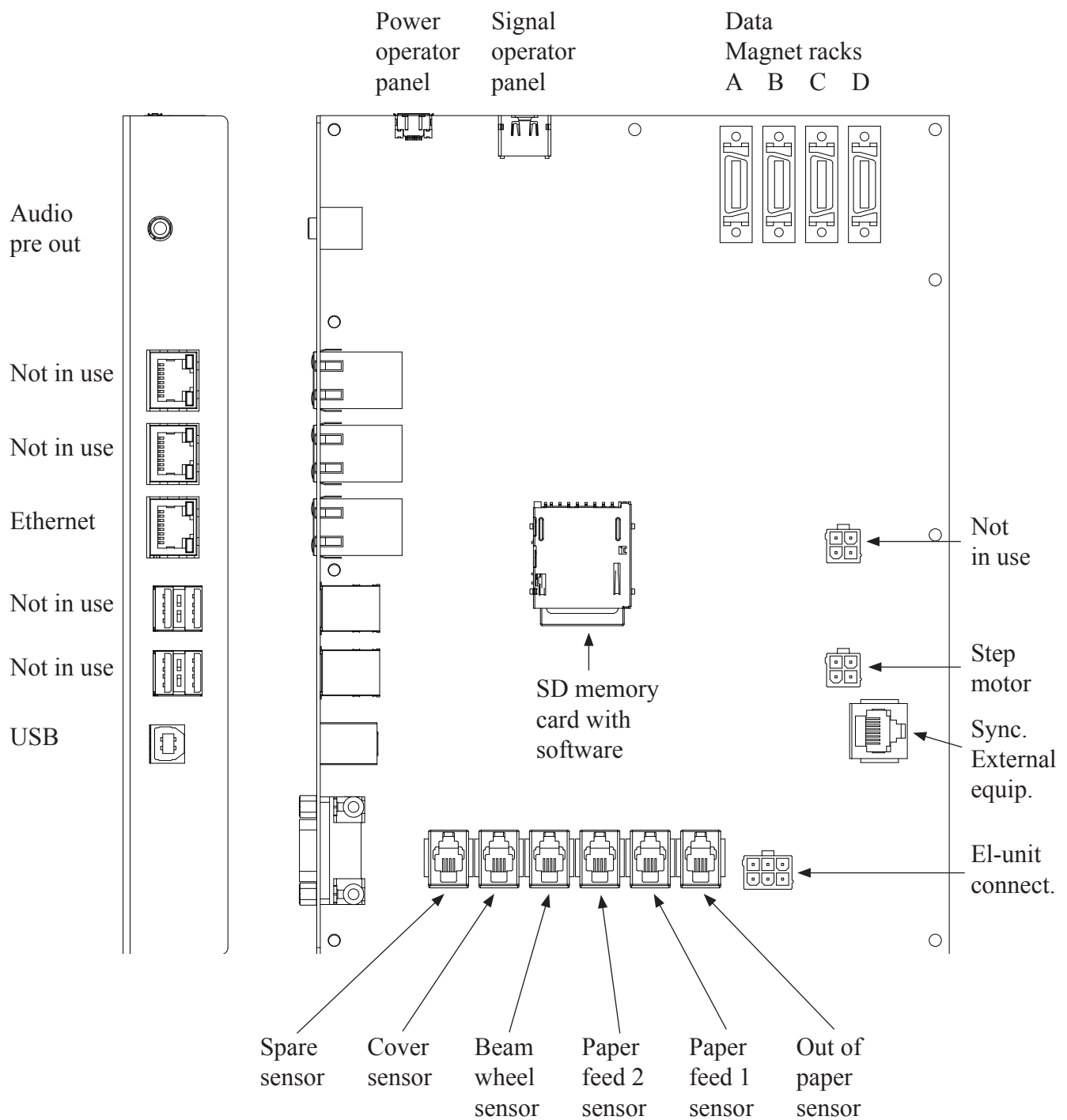

6.5 Escape-sequences

What is an escape-sequence?

An escape-sequence is just a name for a code which is sent to the printer from the computer to change the parameters which control the way the printer works. All parameters that can be set via the operator panel, can also be changed with escape-sequences, (except those for the data communication, i.e. active port, baud rate, data bit, stop bit, and parity).

This makes it possible to have different codes (read; escape-sequences) stored in a document. So, when the document is sent to the printer, these codes are sent first and the printer sets itself in the correct mode and format automatically.



Note! When the printer receives an escape-sequence, it will have first priority. This means, regardless of the setting made before and regardless what the operator panel dictates, the most recent escape-sequence will take precedence.



Note! Escape-sequences should be placed at the very beginning of the first page on the sheet, (e.g. page 1, 3, 5, 7 ...). However, a software form feed can be placed wherever needed. (If there is a command on the other pages, it will be skipped).

All page formatting which is done on the front page will also format the back of the same sheet. It is for example not possible to have 8 dot Braille on the front page and 6 dot on the back page. It is possible to mix 6 and 8 dot Braille however, as long as it is done on two different sheets.

An overview of the different escape-sequences:

ESC A nn	- Sheet length.	nn can be from 08 to 28 (4 to 14 inches).
ESC B nn	- Line length.	nn can be from 10 to 42 characters.
ESC C n	- Print format.	n can be 0 or 1, single-sided (0) or interpoint (1).
ESC H n	- Page layout.	n can be 0 or 1, normal (0) or Z-fold printing (1).
ESC I n	- Page 1 up/down.	n can be 0 or 1, up (0) or down (1).
ESC J n	- 6 / 8 dot Braille.	n can be 0 or 1, 6 (0) or 8 (1) dot Braille.
ESC M nn	- Line spacing.	nn can be from 0 to 16 step.
ESC N n	- Line single/double.	n can be 0 or 1, single (0) or double line spacing (1).
ESC R n	- Page adjust.	n can be from 0 to 9 lines.
ESC S n	- Form feed mode.	n can be 0 or 1, no form feed (0) or normal form feed (1).
ESC T nn	- Page margin.	nn can be from 0 to 20 step.
ESC 0	- Soft reset	
ESC 1	- Soft form feed	
ESC 4	- Printer ID	



Note! The escape-sequences will be executed immediately if the printer is not running. However, if the printer is running, the escape-sequences will keep their place in the document, and will be executed when this particular page is printed. Also keep in mind that any page formatting command must be kept on the front page of a sheet. Then the command will affect both the front and back page, i.e. one sheet. If there are page formatting commands on the back page of a sheet, these commands will be skipped.

Please see the following explanations on how to combine different values to get the different escape-sequences.

Sheet length:

ESC A nn - Sheet length. nn can be from 4 to 14 inches.

nn can be a number from 8 to 28, corresponding to the length of the sheet in inches times two. (A 12 inch sheet will have the number 24).

Inches	ASCII	HEX
04.0	027 065 048 056	1B 41 30 38
04.5	027 065 048 057	1B 41 30 39
05.0	027 065 049 048	1B 41 31 30
05.5	027 065 049 049	1B 41 31 31
06.0	027 065 049 050	1B 41 31 32
06.5	027 065 049 051	1B 41 31 33
07.0	027 065 049 052	1B 41 31 34
07.5	027 065 049 053	1B 41 31 35
08.0	027 065 049 054	1B 41 31 36
08.5	027 065 049 055	1B 41 31 37
09.0	027 065 049 056	1B 41 31 38
09.5	027 065 049 057	1B 41 31 39
10.0	027 065 050 048	1B 41 32 30
10.5	027 065 050 049	1B 41 32 31
11.0	027 065 050 050	1B 41 32 32
11.5	027 065 050 051	1B 41 32 33
12.0	027 065 050 052	1B 41 32 34
12.5	027 065 050 053	1B 41 32 35
13.0	027 065 050 054	1B 41 32 36
13.5	027 065 050 055	1B 41 32 37
14.0	027 065 050 056	1B 41 32 38

Default is 12 inches.

Line length:

ESC B nn - Line length. nn can be from 10 to 42 characters.

Char	ASCII	HEX
10	027 066 049 048	1B 42 31 30
11	027 066 049 049	1B 42 31 31
12	027 066 049 050	1B 42 31 32
13	027 066 049 051	1B 42 31 33
14	027 066 049 052	1B 42 31 34
15	027 066 049 053	1B 42 31 35
16	027 066 049 054	1B 42 31 36
17	027 066 049 055	1B 42 31 37
18	027 066 049 056	1B 42 31 38
19	027 066 049 057	1B 42 31 39
20	027 066 050 048	1B 42 32 30
21	027 066 050 049	1B 42 32 31
22	027 066 050 050	1B 42 32 32
23	027 066 050 051	1B 42 32 33
24	027 066 050 052	1B 42 32 34
25	027 066 050 053	1B 42 32 35
26	027 066 050 054	1B 42 32 36
27	027 066 050 055	1B 42 32 37
28	027 066 050 056	1B 42 32 38
29	027 066 050 057	1B 42 32 39
30	027 066 051 048	1B 42 33 30
31	027 066 051 049	1B 42 33 31
32	027 066 051 050	1B 42 33 32
33	027 066 051 051	1B 42 33 33
34	027 066 051 052	1B 42 33 34
35	027 066 051 053	1B 42 33 35
36	027 066 051 054	1B 42 33 36
37	027 066 051 055	1B 42 33 37
38	027 066 051 056	1B 42 33 38
39	027 066 051 057	1B 42 33 39
40	027 066 052 048	1B 42 34 30
41	027 066 052 049	1B 42 34 31
42	027 066 052 050	1B 42 34 32

Default is 42 characters per. line.

Print Format:

ESC C n - Print Format.
n can be 0 (single-sided) or 1 (interpoint).

Print Format	ASCII	HEX
Single-sided	027 067 048	1B 43 30
Double-sided	027 067 049	1B 43 31

Default is Double-sided.

Page layout:

ESC H n - Page Layout.
n can be 0 (normal) or 1 (Z-fold printing).

Page Layout	ASCII	HEX
Normal	027 072 048	1B 48 30
Z-fold	027 072 049	1B 48 31

Default is Normal Page Layout.

Page 1 up or down:

ESC I n - Page 1 up/down.
n can be 0 (up) or 1 (down).

Page 1	ASCII	HEX
Up	027 073 048	1B 49 30
Down	027 073 049	1B 49 31

Default is Page 1 Up.

6 / 8 dot Braille:

ESC J n - 6 / 8 dot Braille.
n can be 0 (6) or 1 (8 dot Braille).

Braille	ASCII	HEX
6 dot	027 074 048	1B 4A 30
8 dot	027 074 049	1B 4A 31

Default is 6 dot Braille.

Line spacing:

ESC M nn - Line Spacing.
nn can be from 0 to 16 step.

Step	mm	ASCII	HEX
0	0.0000	027 077 048 048	1B 4D 30 30
1	0.3175	027 077 048 049	1B 4D 30 31
2	0.6350	027 077 048 050	1B 4D 30 32
3	0.9525	027 077 048 051	1B 4D 30 33
4	1.2700	027 077 048 052	1B 4D 30 34
5	1.5875	027 077 048 053	1B 4D 30 35
6	1.9050	027 077 048 054	1B 4D 30 36
7	2.2225	027 077 048 055	1B 4D 30 37
8	2.5400	027 077 048 056	1B 4D 30 38
9	2.8575	027 077 048 057	1B 4D 30 39
10	3.1750	027 077 049 048	1B 4D 31 30
11	3.4925	027 077 049 049	1B 4D 31 31
12	3.8100	027 077 049 050	1B 4D 31 32
13	4.1275	027 077 049 051	1B 4D 31 33
14	4.4450	027 077 049 052	1B 4D 31 34
15	4.7625	027 077 049 053	1B 4D 31 35
16	5.0800	027 077 049 054	1B 4D 31 36

16 steps are the standard line spacing (5.08 mm or 0.2”), 8 is the setting for making dots continuously down the sheet (line spacing is 2.54 mm or 0.1”). Note that if the setting is less than 7, and there is text on each line, the dots might get damaged in the printing process.

Default is 16 steps.

Single / Double Line Spacing:

ESC N n - Line Single/Double.
n can be 0 (single) or 1 (double) line spacing

Line Spacing	ASCII	HEX
Single	027 078 048	1B 4E 30
Double	027 078 049	1B 4E 31

The function “Single or Double line spacing” will double the given line spacing. If, e.g. the current line spacing is 13 steps (4.1275 mm), selecting Double line spacing will increase it to 26 steps (8.2550 mm).

Default is Single Line Spacing.

Page Adjust:

ESC R n - Page adjust.
n can be from 0 to 9 lines.

Please keep in mind that there is a difference in the terms “page length” and “sheet length”. By page length we mean the number of lines of text to be printed on a page, and by sheet length we mean the physical size of a sheet of paper in inches.

The number of lines which can be printed on a page, is dependent on whether 6 or 8 dot Braille is used, whether what kind of line spacing is in use, and whether page length is set for Maximum, Maximum-1 or up to -9.

Omitted

Lines	ASCII	HEX
0	027 082 048	1B 52 30
1	027 082 049	1B 52 31
2	027 082 050	1B 52 32
3	027 082 051	1B 52 33
4	027 082 052	1B 52 34
5	027 082 053	1B 52 35
6	027 082 054	1B 52 36
7	027 082 055	1B 52 37
8	027 082 056	1B 52 38
9	027 082 057	1B 52 39

This setting will decrease the number of lines on each page from 1 to 9, (depending on the selected number). If, the maximum number of lines could be 29, and the setting “Max-4” is selected, the resulting number of lines will be 25. On interpoint, this function will centre the text vertically on the page and keep the top and bottom margin approximately equal. On single sided, it will keep the top margin constant and only the bottom margin will vary.

Default is Maximum number of lines per page.

Form Feed Mode:

ESC S n - Form Feed Mode.
n can be 0 (no form feed) or 1 (normal form feed)

Form Feed Mode	ASCII	HEX
No Form Feed	027 083 048	1B 53 30
Normal Form Feed	027 083 049	1B 53 31

Default is Normal Form Feed.

Page Margin:

ESC T nn - Page margin.
nn can be from 0 to 20 step.

Step	mm	ASCII	HEX
0	0.0000	027 084 048 048	1B 54 30 30
1	0.6350	027 084 048 049	1B 54 30 31
2	1.2700	027 084 048 050	1B 54 30 32
3	1.9050	027 084 048 051	1B 54 30 33
4	2.5400	027 084 048 052	1B 54 30 34
5	3.1750	027 084 048 053	1B 54 30 35
6	3.8100	027 084 048 054	1B 54 30 36
7	4.4450	027 084 048 055	1B 54 30 37
8	5.0800	027 084 048 056	1B 54 30 38
9	5.7150	027 084 048 057	1B 54 30 39
10	6.3500	027 084 049 048	1B 54 31 30
11	6.9850	027 084 049 049	1B 54 31 31
12	7.6200	027 084 049 050	1B 54 31 32
13	8.2550	027 084 049 051	1B 54 31 33
14	8.8900	027 084 049 052	1B 54 31 34
15	9.5250	027 084 049 053	1B 54 31 35
16	10.1600	027 084 049 054	1B 54 31 36
17	10.7950	027 084 049 055	1B 54 31 37
18	11.4300	027 084 049 056	1B 54 31 38
19	12.0650	027 084 049 057	1B 54 31 39
20	12.7000	027 084 050 048	1B 54 32 30

The “Page Margin” function will adjust the page margin in steps from 0 to 20. The standard setting is 8, (8 = normal). The page margin will give different effect when used on single-sided, compared with double-sided. On double-sided printing, one step is equal to 0.6350 mm, and the text will be centred vertically on the page. If, e.g. a page margin on 6 steps is selected, the printer will print closer to the edges of the paper, and if a page margin on 20 steps is selected, it will give a larger page margin. This will affect both top and bottom margins, i.e. page margin. On single-sided printing, however, the page margin will actually work as a top margin. (Note! The page layout must be set to normal). One step is equal to 0.6350 mm. It will “push” the text downwards the sheet. If the text reaches the bottom, (meaning that there will not be enough space on this page for the last line), this line will wrap over to the next page.

Default is 8 steps.

Software Reset:

ESC 0 - Soft Reset

This command is used to reset the Printer. It is used from the computer and has the same effect as pushing the key RESET PRINTER. Software Reset should be used with care: If the printer has not finished printing, the rest of the text in the buffer will be lost, and a new paper position will be assumed by the Printer. Because of this, the command is only to be used after a software form feed has been executed, and the Printer has stopped completely.

	ASCII	HEX
Software Reset	027 048	1B 30

Software Form Feed:

ESC 1 - Soft Form Feed

This command is to be used after all text in one volume has been transmitted to the Printer. If text corresponding to less than two pages, or text with an odd number of pages is received, and not followed by FF on the last page, the Printer will wait for more text or FF. This means that the last page may be stuck in the Printer. This is due to the double-sided printing of the Printer. This command makes the Printer to start printing the rest of the text. After this the paper position will be the same as it had when this volume of text was started. Then page no. 1 on the next volume will start out correctly. There will always be at least one blank sheet of paper between the volumes of text when finishing each volume with a Software Form Feed.

	ASCII	HEX
Software Form Feed	027 049	1B 31

Printer ID:

ESC 4 - Adding the Printer ID

When you have several Braille Printers producing the same Braille material, it is not always easy to later figure out what Printer made which book. It is therefore possible to add a Printer ID to the last line on a sheet. There is no matter where the escape-sequence is placed on the page, the ID will always be printed on the last line. Meaning, if you send this escape-sequence on the last page of every print job, you will get the Printer ID printed on the last line on the last page.

The Printer ID is a 5 digit code that has to be set in the menu choice: *Main menu - Printer Setup - Printer ID*. See figure below:

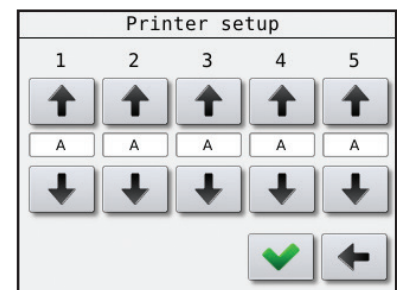

7. GENERAL INFORMATION

7.1 Declaration of conformity

Norway

The manufacturer hereby declares that the **Braille Production Printer 300** from **serial no: 201001** starting from production year 2012:

Is designed and produced in accordance with the in accordance with the requirement of the European Parliament and Council Directive 2006/42/EC of 29th December 2009, on the approximation of the laws of the Member States relating to machinery as implemented in Norway through Arbeidstilsynets Forskrift om Maskiner of 20th May 2009 No. 544 (implemented from 29th December 2009) and conforms to the essential health and safety requirements according to the New Machine Directive (2006/42/EC).

Is in compliance with the European Parliament and Council RoHS (Restriction of Hazardous Substances) Directive 2002/95/EC and do not contain any of the six banned substances: lead, mercury, cadmium, hexavalent chromium, poly-brominated biphenyls (PBB) or polybrominated diphenyl ethers (PBDE), in quantities exceeding maximum concentration values.

Is designed and produced in accordance with European Parliament and Council Directive 2006/95/EC of 12th December 2006 on the harmonization of the laws of the Member States relating to electrical equipment for use within certain voltage limits (The Low Voltage Directive).

Is designed for use in Office Environment and Light Industry and that it is designed and produced to comply with the European Parliament and Council EMC Directive 2004/108/EC on the approximation of the laws of the member States relating to Electromagnetic Compatibility.

Tested according to:

EN 55022 (2006) + A1 (2007) + A2 (2010)

EN 61000-3-2 (2006) + A1 (2009) + A2 (2009)

EN 61000-3-3 (2008)

EN 55024 (1998) + A1 (2001) + A2 (2003)

The CE marking is applied from year 2011.

Signed: Stjørdal, 25th January 2012 on behalf of Braillo Norway AS

Managing Director

Patrick N. Nunnelly

Title

Name

Signature

7.2 Warranty

This product left the factory in a good working condition in accordance with the technical specifications and carries a warranty of 2 years on parts valid from the date of delivery from Braillo Norway A/S.

The warranty includes:

- Replacement of defect part(s)
- Shipping cost for the replaced part(s)

The warranty excludes:

- On-site part replacement (labour, travelling and living expenses for a service engineer)
- Shipping costs for sending the faulty unit back to Braillo Norway A/S (see below).
- Altered product (except as authorized by Braillo Norway A/S) or product not installed or maintained in accordance with Braillo Norway's instructions.
- Customs and duties
- Incidents involving Force Major (for example flooding, earth quake etc. damaging the product).

Should a replacement part be required, please do the following:

Send us a "Warranty request form". Please refer to the next page to see the actual form. The form can also be found on the enclosed CD-ROM. After completing the form, please return it to Braillo Norway A/S by e-mail, fax or regular mail. When received, the parts will be shipped as soon as possible.

What to do with the defective part(s):

If a communication has been made to our service department, and an approval has been given, it will not be necessary to return the part(s) to Braillo Norway A/S. In all other cases, the part(s) must be returned to Braillo Norway A/S as soon as possible. If the part(s) has/have not been received by Braillo Norway A/S within 2 months from the date of issuing the "Warranty request form", this is no longer regarded as a warranty matter and an invoice will be issued and sent.

Warranty request form

(Only one printer/part per document)

Customer name:		Date:
Contact person:		
Phone number:	E-mail address:	
Printer type:	Printer number:	
Part name:	Part number:	

Reason for return:

Comments:

Return to: Braillo Norway A/S Wesselveg 1 7502 Stjørdal Norway	Phone number: +47 74 84 04 40 Fax number: +47 74 84 04 41 E-mail: service@braillo.com
--	---

If this document is not returned within two weeks of origination
 We will assume that it is not required and it will be cancelled.

Internal use only:	
Garanti?	
Kunde belastes	
Kommentarer på reparasjon	

7.3 Addresses and phone numbers

Web: www.braillo.com

Administration/Sales department Braillo Norway AS:

Office: Storgt. 31, Tønsberg

Mail: P.O.Box 447
3101 Tønsberg
Norway

Phone: +47 33 00 28 70

Telefax: +47 33 00 28 71

e-mail: braillo@braillo.com

Service Braillo Norway AS:

Office: Wessels veg 1, Stjørdal

Mail: P.O.Box 93
7501 Stjørdal
Norway

Phone: +47 74 84 04 40

Telefax: +47 74 84 04 41

e-mail: service@braillo.com